

STYLUS



OWNER'S MANUAL

Pride
Mobility Products Corp.
www.pridemobility.com

1-800-800-8586 (US) 1-888-570-1113 (Canada)

SAFETY GUIDELINES



WARNING! An authorized Pride Provider or a qualified technician must perform the initial setup of this wheelchair and must perform all of the procedures in this manual.

The symbols below are used throughout this owner's manual and on the wheelchair to identify warnings and important information. It is very important for you to read them and understand them completely.



WARNING! Indicates a potentially hazardous condition/situation. Failure to follow designated procedures can cause either personal injury, component damage, or malfunction. On the product, this icon is represented as a black symbol on a yellow triangle with a black border.



MANDATORY! These actions should be performed as specified. Failure to perform mandatory actions can cause personal injury and/or equipment damage. On the product, this icon is represented as a white symbol on a blue dot with a white border.



PROHIBITED! These actions are prohibited. These actions should not be performed at any time or in any circumstances. Performing a prohibited action can cause personal injury and/or equipment damage. On the product, this icon is represented as a black symbol with a red circle and red slash.

Quick Reference Information

Authorized Pride Provider: _____

Address: _____

Phone Number: _____

Purchase Date: _____

NOTE: This owner's manual is compiled from the latest specifications and product information available at the time of publication. We reserve the right to make changes as they become necessary. Any changes to our products may cause slight variations between the illustrations and explanations in this manual and the product you have purchased. The latest/current version of this manual is available on our website.

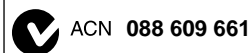

Copyright © 2008

Pride Mobility Products Corp.

INFMANU2121/Rev D/March 2008

C O N T E N T S

I. INTRODUCTION.....	4
II. SAFETY	5
III. YOUR WHEELCHAIR	14
IV. COMFORT ADJUSTMENTS.....	17
V. CARE AND MAINTENANCE	24
VI. WARRANTY	28
APPENDIX I: SPECIFICATIONS.....	29

I . I N T R O D U C T I O N

SAFETY

WELCOME to Pride Mobility Products Corporation (Pride). The wheelchair you have purchased combines state-of-the-art components with **safety**, comfort, and styling in mind. We are confident that these design features will provide you with the conveniences you expect during your daily activities. Once you understand how to **safely** operate and care for your wheelchair, it should give you years of trouble free operation and service.

Read and follow all instructions, warnings, and notes in this manual before attempting to operate your wheelchair for the first time. You must also read all instructions, warnings, and notes contained in any supplemental instructional booklets that accompanied your wheelchair before initial operation. Your **safety** depends upon you, as well as your provider, caretaker, or healthcare professional in using good judgement.

If there is any information in this manual which you do not understand, or if you require additional assistance for setup or operation, please contact your authorized Pride Provider. **Failure to follow the instructions in this manual and those located on your wheelchair can lead to personal injury and/or damage to the wheelchair, including voiding the warranty.**

PURCHASER'S AGREEMENT

By accepting delivery of this product, you promise that you will not change, alter, or modify this product or remove or render inoperable or unsafe any guards, shields, or other safety features of this product; fail, refuse, or neglect to install any retrofit kits from time to time provided by Pride to enhance or preserve the safe use of this product.

SHIPPING AND DELIVERY

Before using your wheelchair, make sure your delivery is complete as some components may be individually packaged. If you do not receive a complete delivery, please contact your authorized Pride Provider immediately. Where damage has occurred during transport, either to the packaging or content, please contact the delivery company responsible.

INFORMATION EXCHANGE

We want to hear your questions, comments, and suggestions about this manual. We would also like to hear about the safety and reliability of your new wheelchair, and about the service you received from your authorized Pride Provider.

Please notify us of any change of address, so we can keep you apprised of important information about safety, new products, and new options that can increase your ability to use and enjoy your wheelchair. Please feel free to contact us at one of the following addresses:

USA:

Pride Mobility Products Corporation
Attn.: Customer Care Department
182 Susquehanna Avenue
Exeter, PA 18643-2694
customercare@pridemobility.com
1-800-424-8205

Canada:

Pride Mobility Products Company
380 Vansickle Road Unit 350
St. Catharines, Ontario L2R 6P7
1-888-570-1113

NOTE: If you ever lose or misplace your product registration card or your copy of this manual, contact us and we will be glad to send you a new one immediately.

II. SAFETY

PRODUCT SAFETY SYMBOLS

The symbols below are used on the wheelchair to identify warnings, mandatory actions, and prohibited actions. It is very important for you to read and understand them completely.



Read and follow the information in the owner's manual.



Maximum seating weight.



Keep your hands away from the tires when driving. Be aware that loose fitting clothing can become caught in drive tires.



Avoid exposure to rain, snow, ice, salt, or standing water whenever possible. Maintain and store in a clean and dry condition.



Do not lift the mobility vehicle while seated in it.



Do not lift the mobility vehicle while seated in it.

II. SAFETY



Disposal and recycling - Contact your authorized Pride Provider for information on proper disposal and recycling of your Pride product and its packaging.



II. SAFETY

GENERAL GUIDELINES



MANDATORY! Do not operate your new wheelchair for the first time without completely reading and understanding this owner's manual.

Your wheelchair is a state-of-the-art life-enhancement device designed to increase mobility. Pride provides an extensive variety of products to best fit the individual needs of the wheelchair user. Please be aware that the final selection and purchasing decision regarding the type of wheelchair to be used is the responsibility of the wheelchair user, who is capable of making such a decision, and his/her healthcare professional (i.e., medical doctor, physical therapist, etc.).

The contents of this manual are based on the expectation that a mobility device expert has properly fitted the wheelchair to the user and has assisted the prescribing healthcare professional and/or the authorized Pride Provider in the instruction process for the use of the product.

There are certain situations, including some medical conditions, where the wheelchair user will need to practice operating the wheelchair in the presence of a trained attendant. A trained attendant can be defined as a family member or care professional specially trained in assisting a wheelchair user in various daily living activities.

As you begin using your wheelchair during daily activities, you will probably encounter situations in which you will need some practice. Simply take your time and you will soon be in full and confident control as you maneuver through doorways, on and off of elevators, up and down ramps, and over moderate terrain.

Below are some precautions, tips, and other safety considerations that will help you become accustomed to operating your wheelchair safely.

Modifications

Pride has designed and engineered your wheelchair to provide maximum mobility and utility. A wide range of accessories is available from your authorized Pride Provider to further customize your wheelchair to better suit your needs and/or preferences. However, under no circumstances should you modify, add, remove, or disable any feature, part, or function of your wheelchair.



WARNING! Do not modify your wheelchair in any way not authorized by Pride. Do not use accessories if they have not been tested or approved for Pride products.

Pre-Ride Safety Check

Get to know the feel of your wheelchair and its capabilities. Pride recommends that you perform a safety check before each use to make sure your wheelchair operates smoothly and safely.

Perform the following inspections prior to using your wheelchair:

- Check for proper tire inflation. Maintain but do not exceed **65 psi (4.5 bar)** in each tire if equipped with pneumatic tires.
- Check the brakes. See V. "Care and Maintenance."

NOTE: *If you discover a problem, contact your authorized Pride Provider for assistance.*

II. SAFETY

Weight Limitations

Your wheelchair is rated for a maximum weight capacity. Please refer to the specifications table for this limit.



MANDATORY! Stay within the specified weight capacity of your wheelchair. Exceeding the weight capacity voids your warranty. Pride will not be held responsible for injuries and/or property damage resulting from failure to observe weight limitations.



WARNING! Do not carry passengers on your wheelchair. Carrying passengers on your wheelchair may affect the center of gravity, resulting in a tip or a fall.

WARNING! The rear flap is for pocket items such as cell phones, keys, and papers. There are no other storage areas on your wheelchair. Carrying heavy baggage or tying heavy baggage to your wheelchair may affect the center of gravity, resulting in a tip or a fall.

Tire Inflation

If your wheelchair is equipped with pneumatic tires, you should check or have the air pressure checked regularly. Proper inflation pressures will prolong the life of your tires and help ensure the smooth operation of your wheelchair.



WARNING! It is important that 65 psi (4.5 bar) tire pressure be maintained in pneumatic tires at all times. Do not underinflate or overinflate your tires. Low pressure may result in loss of control, and overinflated tires may burst. Failure to maintain 65 psi (4.5 bar) tire pressure in pneumatic tires at all times may result in tire and/or wheel failure.

WARNING! Inflate your wheelchair drive tires from a regulated air source with an available pressure gauge. Inflating your tires from an unregulated air source could overinflate them, resulting in a burst tire.

Incline Information

More and more buildings have ramps with specified degrees of inclination, designed for easy and safe access. Some ramps may have turning switchbacks (180-degree turns) that require you to have good cornering skills on your wheelchair.

- Proceed with extreme caution as you approach the downgrade of a ramp or other incline.
- Take wide swings with your wheelchair's front wheels around any tight corners. If you do that, the wheelchair's rear wheels will follow a wide arc, not cut the corner short, and not bump into or get hung up on any railing corners.
- When driving down a ramp, proceed slowly to ensure a safely controlled descent.
- Avoid sudden stops and starts.

When climbing an incline, try to keep your wheelchair moving. If you must stop, start up again slowly and then accelerate cautiously. When driving down an incline, proceed slowly and drive in the forward direction only. If your wheelchair starts to move down the incline faster than you anticipated or desired, bring it to a complete stop using both hands, then proceed slowly to ensure a safely controlled descent.



WARNING! When on any sort of an incline or decline, never allow the wheelchair to roll freely while seated on it or standing next to it.

WARNING! When climbing an incline, do not zigzag or drive at an angle up the face of the incline. Drive your wheelchair straight up the incline. This greatly reduces the possibility of a tip or a fall. Always exercise extreme caution when negotiating an incline.

WARNING! You should not travel up or down a potentially hazardous incline (i.e., areas covered with snow, ice, cut grass, or wet leaves).



WARNING! Never travel down an incline backward. Doing so may cause the wheelchair to tip. Always exercise extreme caution when negotiating an incline.

WARNING! Even though your wheelchair is capable of climbing slopes greater than those illustrated in figure 1, do not, under any circumstances, exceed the incline guidelines or any other specifications presented in this manual. Doing so could cause instability in your wheelchair.

II. SAFETY

All handicap public access ramps are required to have a maximum slope of 5° (8.7%). Therefore, Pride recommends that the maximum slope of an incline you attempt to safely ascend or descend on your wheelchair does not exceed 5° (8.7%). See figure 1.



WARNING! Any attempt to climb or descend a slope steeper than 5° (8.7%) may put your wheelchair in an unstable position and cause it to tip.

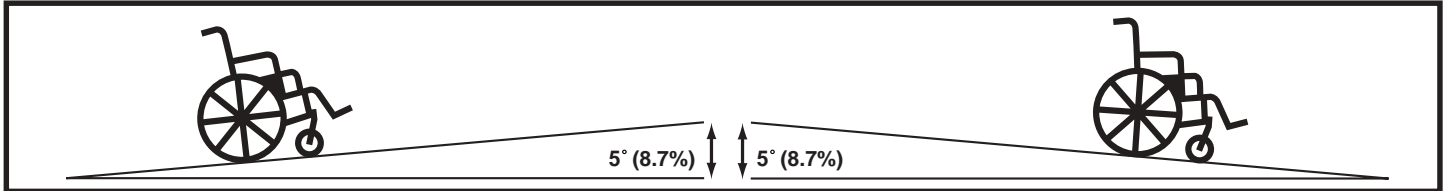

Figure 1. Maximum Safe Slope (Ascending and Descending)

Braking Information

To stop the wheelchair, apply pressure to both handrims until the wheelchair comes to a complete stop.

Manual Park Brakes

Your wheelchair is equipped with two manual park brakes; one mounted on each drive wheel. The manual park brakes help prevent your wheelchair from moving when parked. After you bring your wheelchair to a complete stop, engage both manual park brakes. There are two types of manual park brakes available on your wheelchair: push-to-lock and pull-to-lock. If you have any questions about the operation of your manual park brakes, contact your authorized Pride Provider.



WARNING! Do not attempt to use either manual park brake lever to stop your wheelchair.

Cornering Information

While your wheelchair is equipped with front caster wheels, excessively high cornering speeds can still create the possibility of tipping. Factors which affect the possibility of tipping include, but are not limited to: cornering speed, steering angle (how sharply you are turning), uneven road surfaces, inclined road surfaces, riding from an area of low traction to an area of high traction (such as passing from a grassy area to a paved area – especially at high speed while turning), and abrupt directional changes. High cornering speeds are not recommended. If you feel that you may tip over in a corner, reduce your speed and steering angle (i.e., lessen the sharpness of the turn) to prevent your wheelchair from tipping.



WARNING! When cornering sharply, reduce your speed and maintain a stable center of gravity. This greatly reduces the possibility of a tip or fall.

Public Streets and Roadways



WARNING! You should not operate your wheelchair on public streets and roadways. Be aware that it may be difficult for traffic to see you when you are seated on your wheelchair. Obey all local pedestrian traffic rules. Wait until your path is clear of traffic, and then proceed with extreme caution.

Outdoor Driving Surfaces

Your wheelchair is designed to provide optimum stability under normal driving conditions—dry, level surfaces composed of concrete, blacktop, or asphalt. However, Pride recognizes that there will be times when you will encounter other surface types. For this reason, your wheelchair is designed to perform admirably on packed soil, grass, and gravel. Feel free to use your wheelchair safely on lawns and in park areas.

II. SAFETY

- Reduce your wheelchair's speed when driving on uneven terrain and/or soft surfaces.
- Avoid tall grass that can entangle the running gear.
- Avoid loosely packed gravel and sand.
- Avoid uneven surfaces.
- If you feel unsure about a driving surface, avoid that surface.

Inclement Weather Precautions

Exposure of your wheelchair to inclement weather conditions should be avoided whenever possible. If suddenly caught up in rain, snow, severe cold or heat while operating your wheelchair, proceed to shelter at the earliest opportunity. Thoroughly dry your wheelchair before storing or operating your wheelchair.



PROHIBITED! Operating in rain, snow, salt, mist/spray conditions, and on icy/slippery surfaces can have an adverse affect on your wheelchair. Maintain and store your wheelchair in a dry and clean condition.



WARNING! Prolonged exposure to hot or cold conditions may affect the temperature of upholstered and non-upholstered items on the wheelchair, possibly resulting in skin irritation. Exercise caution when using the wheelchair in extremely hot or cold conditions or when exposing your wheelchair to direct sunlight for prolonged periods of time.

Stationary Obstacles (Steps, Curbs, etc.)

Proceed with extreme caution when driving near raised surfaces, unprotected ledges and/or drop-offs (curbs, porches, stairs, etc.). Be sure your wheelchair is traveling perpendicular to any curb you may be required to navigate. See figure 2.



WARNING! Do not attempt to have your wheelchair climb or descend an obstacle that is higher than 2 in. (5 cm) unless you have the assistance of an attendant.

WARNING! Do not attempt to have your wheelchair proceed backward down any step, curb, or other obstacle. This may cause the wheelchair to tip.

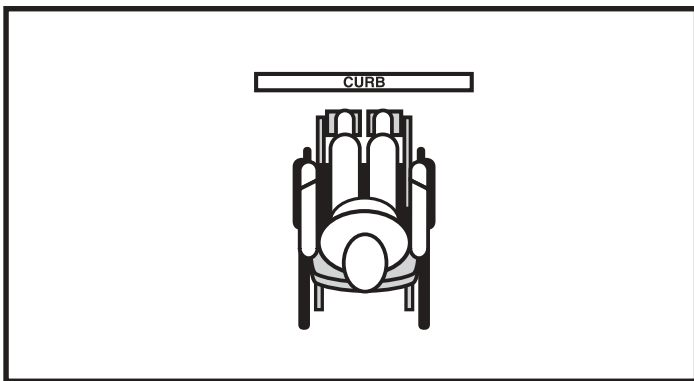

Figure 2. Correct Curb Approach

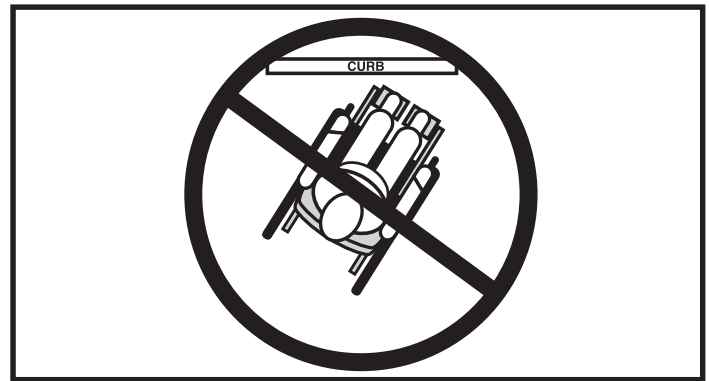

Figure 3. Incorrect Curb Approach

Stairs and Escalators

Wheelchairs are not designed to travel up or down stairs or escalators. Always use an elevator.



WARNING! Never use your wheelchair to negotiate steps or escalators.

Doors

- Determine if the door opens toward or away from you.
- Drive your wheelchair gently and slowly forward to push the door open. Or drive your wheelchair gently and slowly backward to pull the door open.

II. SAFETY

Elevators

Modern elevators have a door edge safety mechanism that, when pushed, reopens the elevator door(s).

- If you are in the doorway of an elevator when the door(s) begin to close, push on the rubber door edge or allow the rubber door edge to contact the wheelchair and the door will reopen.
- Use care that pocketbooks, packages, or wheelchair accessories do not become caught in elevator doors.

Lift/Elevation Products

If you will be traveling with your wheelchair, you may find it necessary to use a lift/elevation product to aid in transportation. Pride recommends that you closely review the instructions, specifications, and safety information set forth by the manufacturer of the lift/elevation product before using that product.



WARNING! Never sit on your wheelchair when it is being used in connection with any type of lift/elevation product. Your wheelchair was not designed with such use in mind and any damage or injury incurred from such use is not the responsibility of Pride.

Motor Vehicle Transport

Pride recommends that you do not remain seated in your wheelchair while traveling in a motor vehicle. Your wheelchair was designed to be folded and stored in a secure location, such as the trunk of a car, during motor vehicle transport.



WARNING! Do not sit on your wheelchair while it is in a moving vehicle.

Positioning Belts

Your authorized Pride Provider, therapist(s), and other healthcare professionals are responsible for determining your requirement for a positioning belt in order to operate your wheelchair safely. Typically, the positioning belt is not designed for use as a restraining device in a motor vehicle. You should be properly belted into seats approved by the vehicle manufacturer with your wheelchair properly stowed for vehicle transport.



WARNING! If you require a positioning belt to safely operate your wheelchair, make sure it is fastened securely in order to reduce the possibility of a fall from the wheelchair.

WARNING! The positioning belt is not designed for use as a seat belt in a motor vehicle. Nor is your wheelchair suitable for use as a seat in any vehicle. Anyone traveling in a vehicle should be properly belted into seats approved by the vehicle manufacturer.

II. SAFETY

Removable Parts



WARNING! Do not attempt to lift or move a wheelchair by any of its removable parts, including the armrests, seat, and front riggings.

Reaching and Bending

Never reach, lean, or bend while driving your wheelchair. If it is absolutely necessary to reach, lean, or bend while seated on your wheelchair, it is important to maintain a stable center of gravity and keep the wheelchair from tipping. Pride recommends that the wheelchair user determine his/her personal limitations and practice bending and reaching in the presence of a qualified healthcare professional.



WARNING! Do not bend, lean, or reach for objects if you have to pick them up from the floor by reaching down between your knees or if you have to reach over the back of the seat. Movements such as these may change your center of gravity and the weight distribution of the wheelchair. This may cause your wheelchair to tip.



WARNING! Keep your hands away from the tires when driving. Be aware that loose fitting clothing can become caught in drive tires.

Transfers

Transferring onto and off of your wheelchair requires a good sense of balance. Always have an attendant or healthcare professional present while learning to properly transfer yourself.

To eliminate the possibility of injury, Pride recommends that you or a trained attendant perform the following tasks before attempting a transfer:

- Turn both caster wheels toward the transfer destination to improve wheelchair stability during transfer.
- Ensure both manual park brakes on your wheelchair are engaged. See III. “Your Wheelchair.”
- If necessary, remove or flip up one or both armrests. See IV. “Comfort Adjustments.”
- Move the leg rests aside; this will help to keep your feet from getting caught on the front rigging during the transfer.
- Reduce the distance between your wheelchair and the object you are transferring onto.

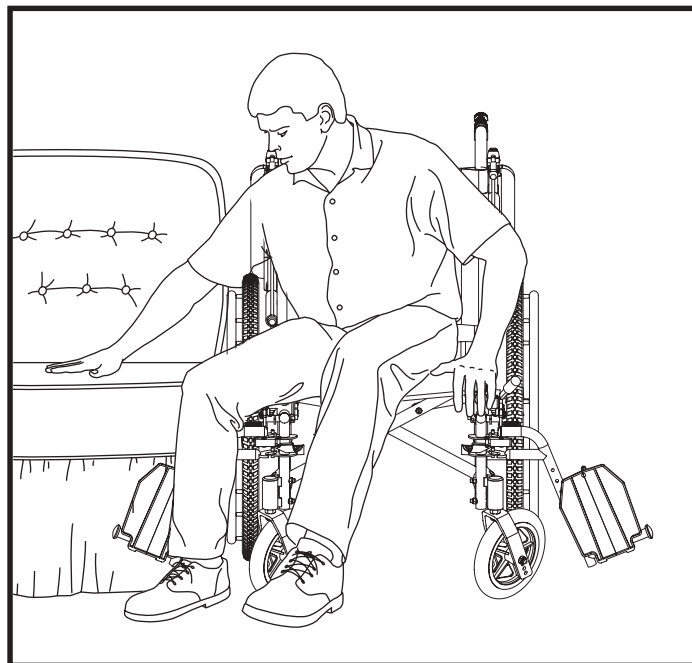

Figure 4. Ideal Transfer Position

WARNING! Before transferring, position yourself as far back as possible in the wheelchair seat to prevent the wheelchair from tipping forward during transfer.



WARNING! Avoid putting all of your weight on the wheelchair armrests and do not use the armrests for weight bearing purposes, such as transfers. Such use may cause the wheelchair to tip, resulting in a fall from the wheelchair and personal injury.

WARNING! Avoid putting all of your weight on the front riggings. Such use may cause the wheelchair to tip.

II. SAFETY

Prescription Drugs/Physical Limitations

Users must exercise care and common sense when operating a wheelchair. This includes awareness of safety issues when taking prescribed or over-the-counter drugs or when the user has specific physical limitations.



WARNING! Consult your physician if you are taking prescribed or over-the-counter medication or if you have certain physical limitations. Some medications and limitations may impair your ability to operate your wheelchair in a safe manner.

Alcohol/Smoking

The wheelchair user must exercise care and common sense when operating his/her wheelchair. This includes awareness of safety issues while under the influence of alcohol or while smoking.

WARNING! Do not operate your wheelchair while you are under the influence of alcohol, as this may impair your ability to operate your wheelchair in a safe manner.



WARNING! Pride strongly recommends that you do not smoke cigarettes while seated in your wheelchair, although the wheelchair has passed the necessary testing requirements for cigarette smoking. You must adhere to the following safety guidelines if you decide to smoke cigarettes while seated in your wheelchair.

- Do not leave lit cigarettes unattended.
- Keep ashtrays a safe distance from the seat cushions.
- Always make sure cigarettes are completely extinguished before disposal.

III. YOUR WHEELCHAIR

THE STYLUS

The Stylus is a rear-wheel drive wheelchair designed to operate both indoors and outdoors on smooth surfaces.

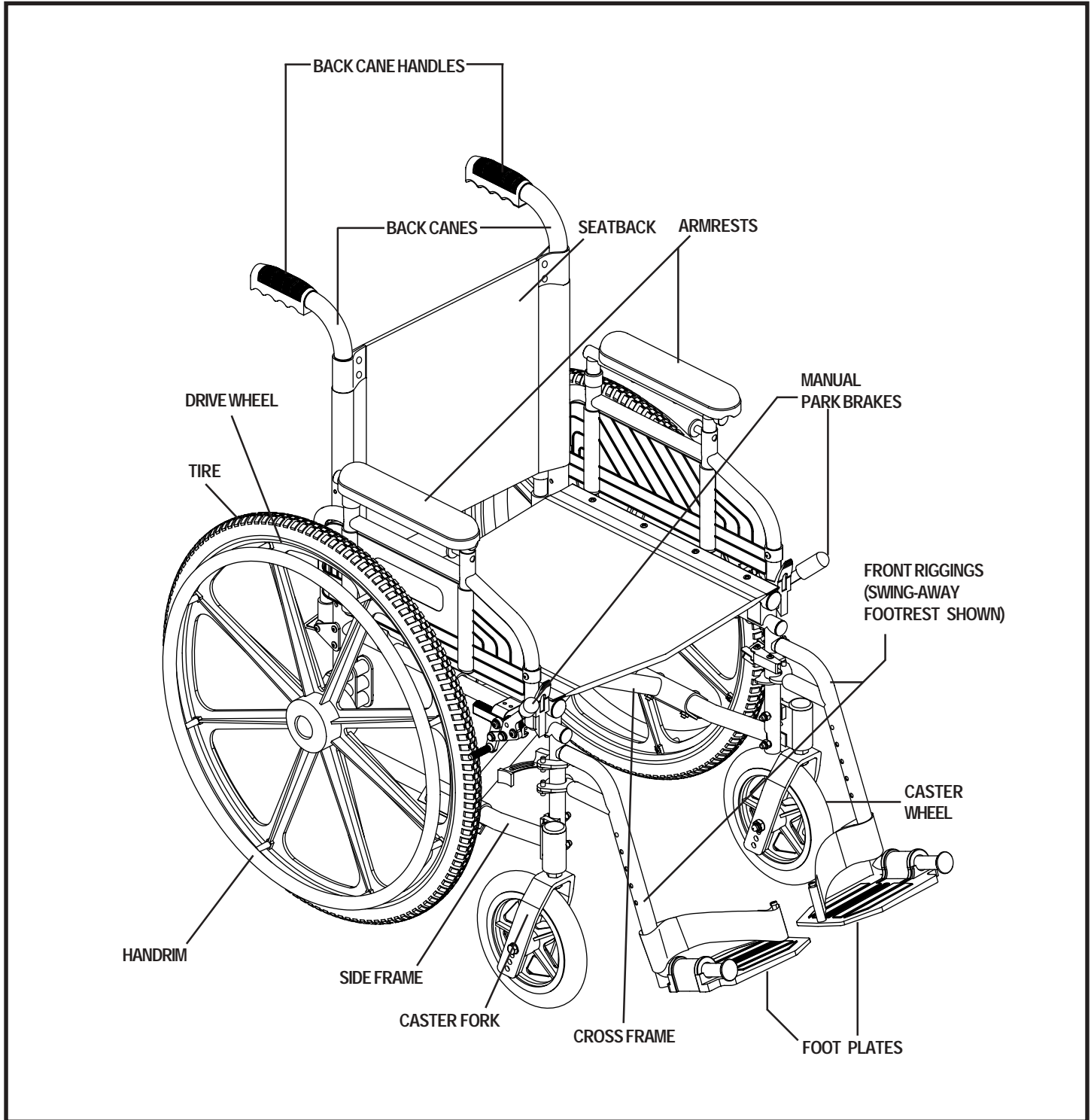

Figure 5. The Stylus Wheelchair0

III. YOUR WHEELCHAIR

USING THE STYLUS

The Stylus is a manual wheelchair. Either an attendant pushes it, or you move it by gripping the handrims (see figure 5) and turning them in the desired direction of travel. You steer it by turning one wheel faster than the other. To stop the wheelchair, you apply pressure to both handrims until the wheelchair comes to a complete stop.

Unfolding

The Stylus is a folding wheelchair. Unfold it completely before sitting in it.

To unfold the LiteStream:

1. Engage both manual park brakes. See figure 6 or 7.
2. Place the palm of your hands on each seat base rail. See figure 8.
3. Press down until the seat base rails are locked into place.

Folding

Folding the wheelchair makes it easier to carry and store. The folded width is 11.75 in. (29.85 cm).

To fold the LiteStream:

1. Engage both manual park brakes. See figure 6 or 7.
2. Flip up the foot plates (if applicable).
3. Hold the seat base by the center at the front and at the back. See figure 9.
4. Pull up on the seat base until both wheels close together.

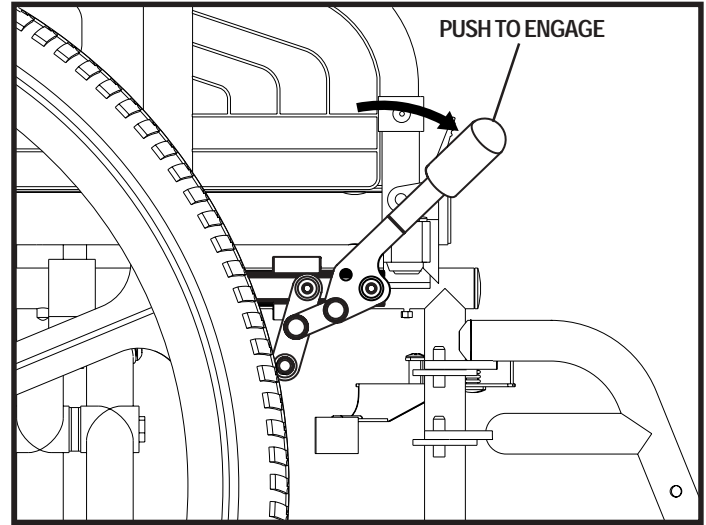

Figure 6. Right Manual Push-to-Lock Park Brake Engaged

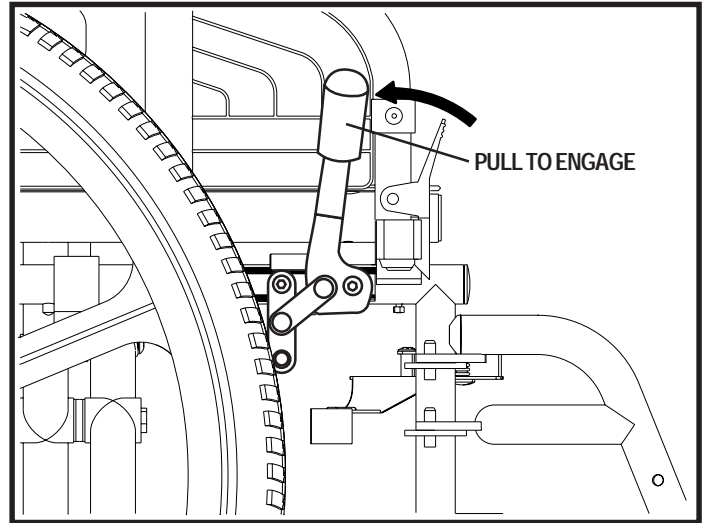

Figure 7. Right Manual Pull-to-Lock Park Brake Engaged

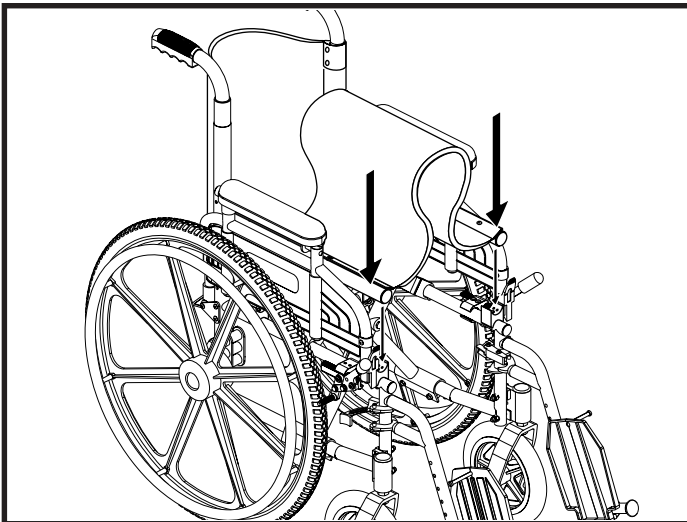

Figure 8. Unfolding the Stylus

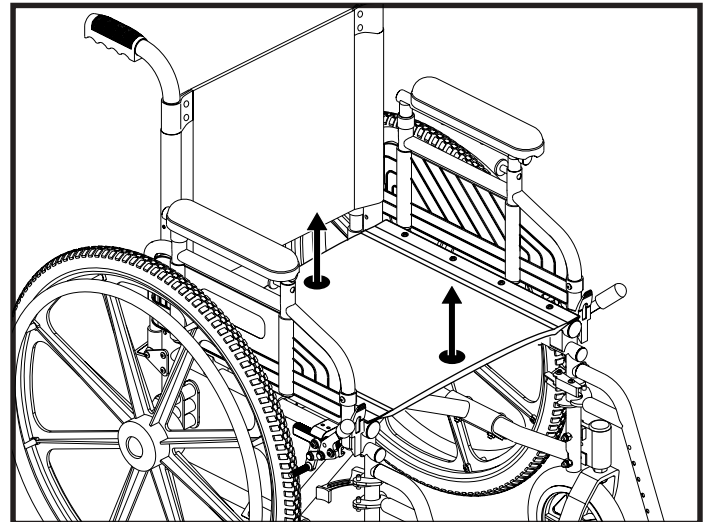

Figure 9. Folding the Stylus

III. YOUR WHEELCHAIR

Transporting Your Stylus

The Stylus was designed to be folded and stored in a secure location, such as the trunk of a car, during motor vehicle transport.

To stow the Stylus:

1. Fold the Stylus.
2. With one hand, grab and squeeze together both back cane handles. See figure 10.
3. With the other hand, grab and squeeze together both seat base rails.

NOTE: You can also remove the drive wheels to make the wheelchair more compact. See “Drive Wheel Position.”



WARNING! If you remove the drive wheels, make sure the quick-release mechanism snaps into place when reinstalling the wheel. See “Drive Wheel Position.”

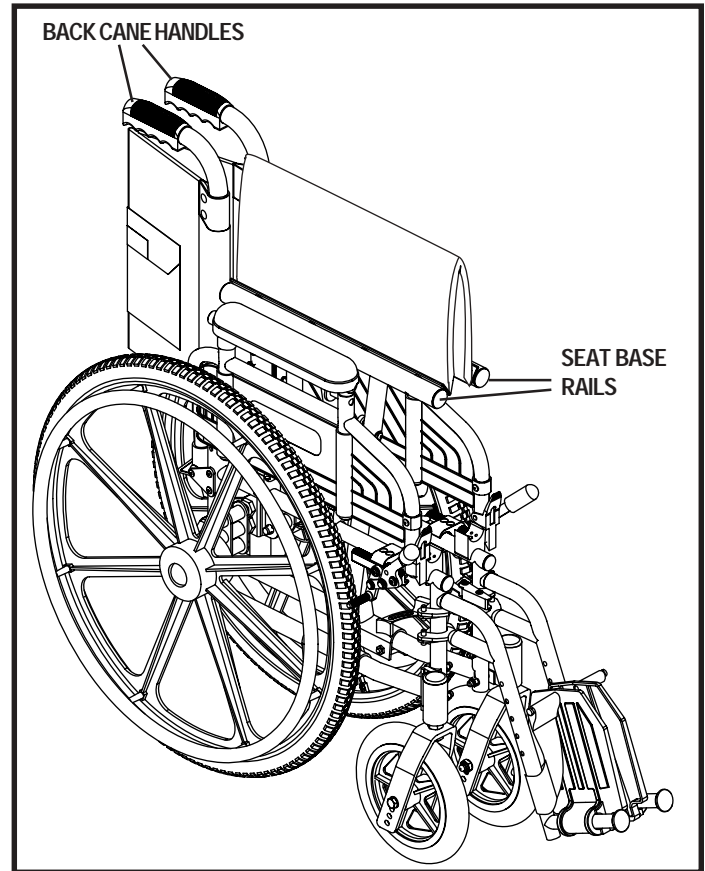

Figure 10. Lifting Points

IV. COMFORT ADJUSTMENTS

COMFORT ADJUSTMENTS

After becoming familiar with your wheelchair's operation, you may find the need to make some adjustments to increase your comfort, such as drive wheel position, swing-away footrest length, elevating leg rest length and angle, calf pad height, seatback height, armrest height, seatback angle, seat angle, manual park brake, seat tension, and caster angle.

WARNING! If your wheelchair was configured by your authorized Pride Provider, please consult your healthcare professional before making any adjustment that may degrade your wheelchair's performance and safety by changing its center of gravity.



WARNING! Some wheelchair components are heavy. You may need assistance to lift or carry them. Please refer to the specifications table for specific component weights before you disassemble the wheelchair.

WARNING! Remove the occupant from the wheelchair before making any adjustments.

You may need the following to make comfort adjustments:

- Metric socket set
- Metric hex key set
- Adjustable wrench

Drive Wheel Adjustment

Your wheelchair is equipped with either a bolt-on or a quick-release drive wheel. The location of the drive wheel center bolt and nut on the axle bracket determines the drive wheel position. The location of the axle bracket on the wheelchair frame determines the drive wheel height and can affect performance and center of gravity.

NOTE: *If you change the drive wheel position, you may have to change the caster height, caster angle, and adjust the manual park brake. Consult your authorized Pride Provider.*

To change the drive wheel position:

1. Remove the drive wheel. If your wheelchair is equipped with a quick-release drive wheel, press the quick-release button and pull the drive wheel off. See figure 11. If your wheelchair is equipped with a bolt-on drive wheel, remove the hubcap, and then remove the nut and bolt. See figure 12.
2. Pull the drive wheel off of the wheelchair.

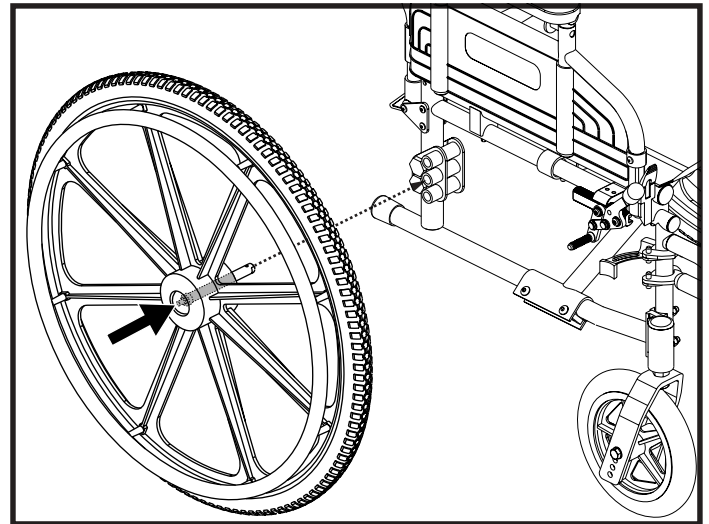

Figure 11. Quick Release Drive Wheel

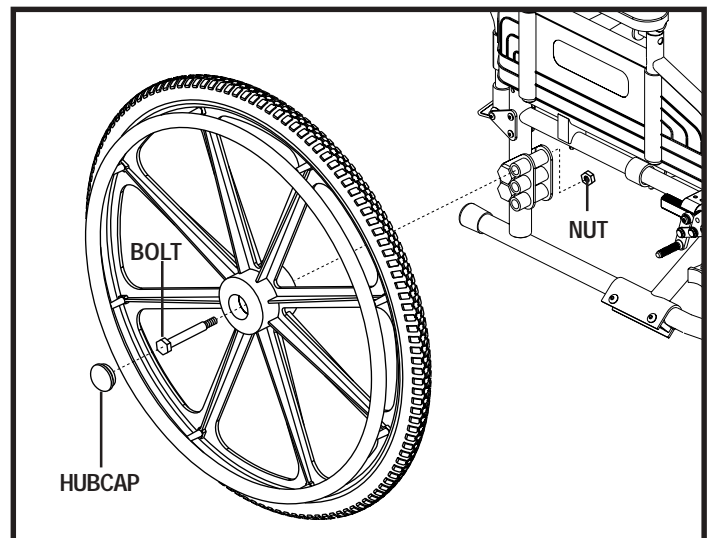

Figure 12. Bolt-on Drive Wheel

IV. COMFORT ADJUSTMENTS

3. Remove the hardware that fastens the drive wheel bracket to the frame. See figure 13.
4. Reposition the drive wheel bracket to desired position (either A or B).
5. Reinstall the hardware that fastens the drive wheel bracket to the frame.
6. Reinstall the drive wheel. Make sure that the wheel axle is snapped securely into the axle bracket or the hardware is reinstalled and securely tightened, depending on which drive wheel your wheelchair is equipped with.

NOTE: Make sure that both drive wheels are adjusted to the same position.

To change the drive wheel height:

1. Remove the drive wheel. If your wheelchair is equipped with a quick-release drive wheel, press the quick-release button and pull the drive wheel off. See figure 11. If your wheelchair is equipped with a bolt-on drive wheel, remove the hubcap, and then remove the nut and bolt. See figure 12.
2. Pull the drive wheel off of the wheelchair.
3. Reposition the drive wheel up or down to the desired position.

NOTE: The wheel height can be adjusted to 3 different positions. See figure 13 for more information on seat-to-floor heights.

3. Reinstall the drive wheel. Make sure that the wheel axle is snapped securely into the axle bracket or the hardware is reinstalled and securely tightened, depending on which drive wheel your wheelchair is equipped with.

NOTE: Make sure that both drive wheels are adjusted to the same position.

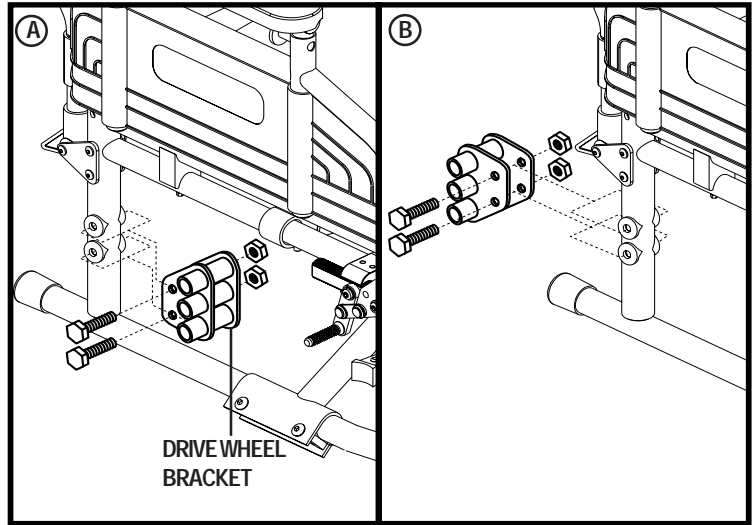

Figure 13. Quick-Release Drive Wheel Position Adjustment

Seat-to-Floor Height Matrix – Quick-Release Wheels			
S-T-F Height	Caster Size	Caster Axle Position*	Drive Wheel Position
19.5 in.	8 in.	3	24 in. / bottom hole
18.5 in.	8 in.	4	24 in. / middle hole
18.5 in.	6 in.	2	24 in. / middle hole
18.5 in.	6 in.	3	22 in. / bottom hole
18.5 in.	8 in.	4	22 in. / bottom hole
17.5 in.	8 in.	4	24 in. / top hole
17.5 in.	8 in.	4	22 in. / top hole
17.5 in.	6 in.	4	24 in. / top hole
17.5 in.	6 in.	4	22 in. / middle hole
16.5 in.	6 in.	4	22 in. / top hole
16.5 in.	5 in.	3	22 in. / middle hole
16.0 in.	5 in.	4	22 in. / top hole
16.0 in.	5 in.	4	20 in. / middle hole

*Hole Position from Bottom

Figure 14. Seat-to-Floor Height Matrix - Quick-Release Drive Wheels



WARNING! Ensure the quick-release axles are properly secured.

IV. COMFORT ADJUSTMENTS

Swing-Away Footrest (SFR) Removal

The Swing-away Footrests (SFR) can be moved or removed to aid in transfers or transporting your wheelchair.

To move the SFR to the side:

1. Push the release lever back. See figure 15
2. Move the SFR aside.
3. Repeat for the other side if necessary.

To remove the SFR:

1. Move the SFR to the side.
2. Pull the SFR up.
3. Repeat for the other side if necessary.

Swing-Away Footrest (SFR) Length

You can change the SFR length between 12-16 in. (30.48-40.64 cm) in 1-in. (2.54-cm) increments. This length is measured from the SFR foot plate to the top of the SFR. See figure 16.

To change the SFR length:

1. Remove the screw from the SFR.
2. Adjust the SFR to the desired length.
3. Reinstall the screw into the SFR.
4. Repeat for the other side.

Elevating Leg Rest (ELR) Length

You can change the ELR length between 15-19 in. (38.1-48.26 cm). This length is measured from the ELR foot plate to the top of the ELR. See figure 17.

To change the ELR length:

1. Loosen the bolt head on the underside of the ELR.

NOTE: You may need to tap the bolt head to release the wedge clamp.

2. Adjust the ELR to the desired length.
3. Tighten the bolt head.
4. Repeat the procedure for the other side.

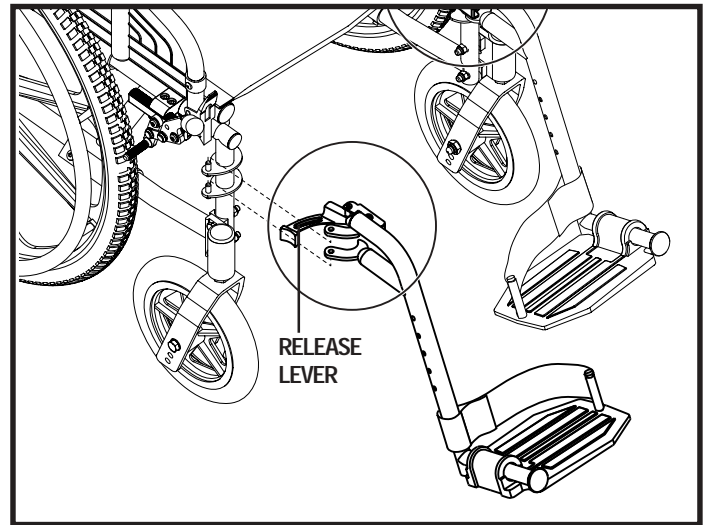

Figure 15. SFR Release

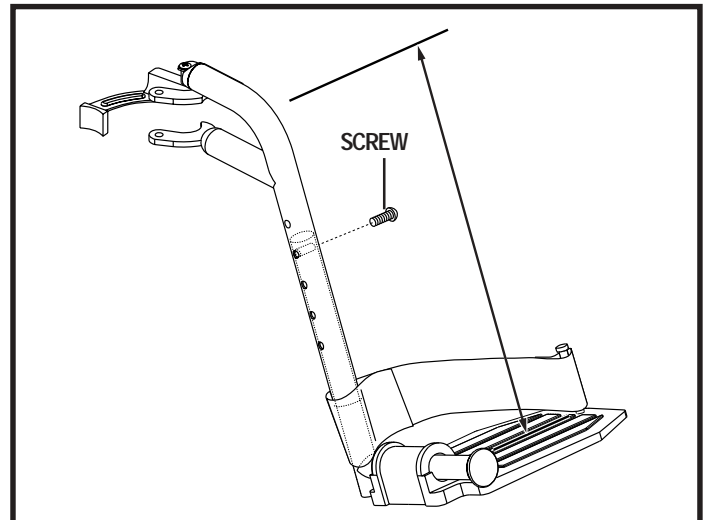

Figure 16. SFR Length Adjustment

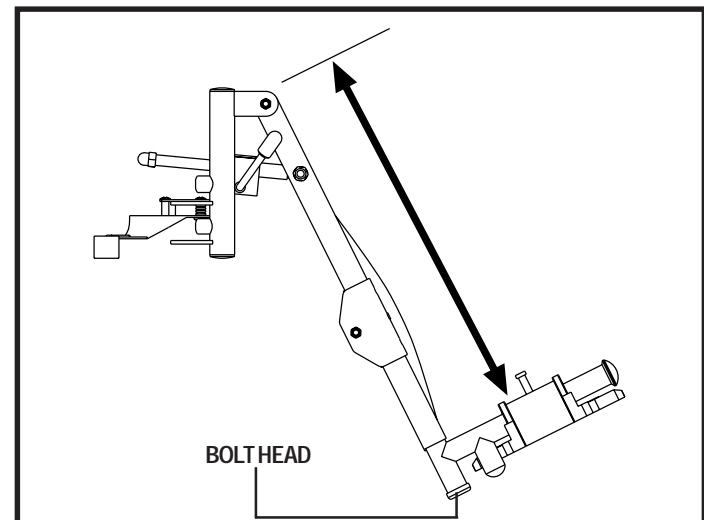

Figure 17. ELR Length Adjustment

IV. COMFORT ADJUSTMENTS

ELR Angle Adjustment

You can change the ELR angle from 70°-0°. See figure 18.

To change the ELR angle:

1. Lift the ELR to the desired position to raise it.
2. To lower the ELR, pull the release lever forward.
3. Lower the ELR to the desired angle.
4. Release the lever to secure the ELR.

ELR Calf Pad Adjustment

You can change the ELR calf pad to one of three different positions. See figure 19.

To change the ELR calf pad position:

1. Rotate the calf pad to unlock it.
2. Move the calf pad up or down to the desired position.
3. Rotate the calf pad back to lock it into place.
4. Repeat for the other side.

Seatback Height Adjustment

You can adjust the seatback to one of three different heights. The adjustment range is 3 in. (7.62 cm) in 1-in. (2.54-cm) increments. See figure 20.

To adjust the seatback height:

1. Remove the bolts that fasten the back canes to each side of the frame.
2. Slide the back canes up or down to the desired height.
3. Reinstall the bolts to refasten the back canes to the frame.

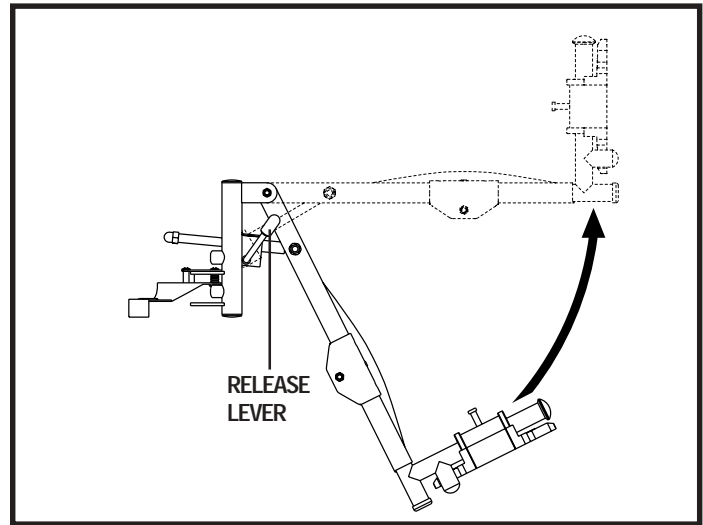

Figure 18. ELR Angle Adjustment

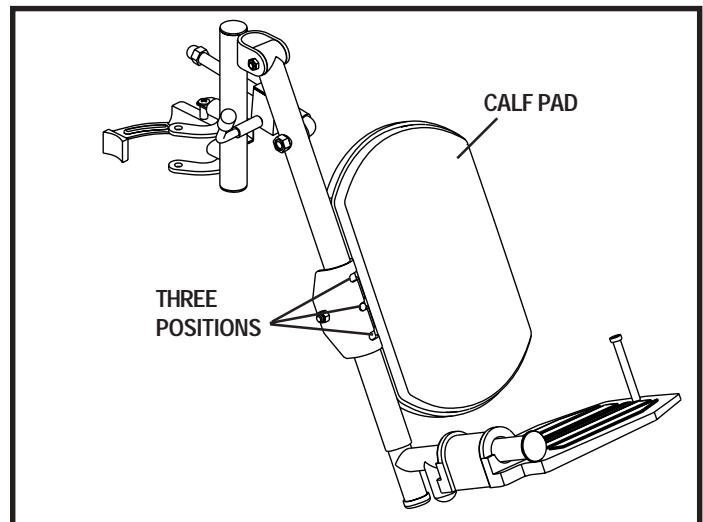

Figure 19. ELR Calf Pad Position Adjustment

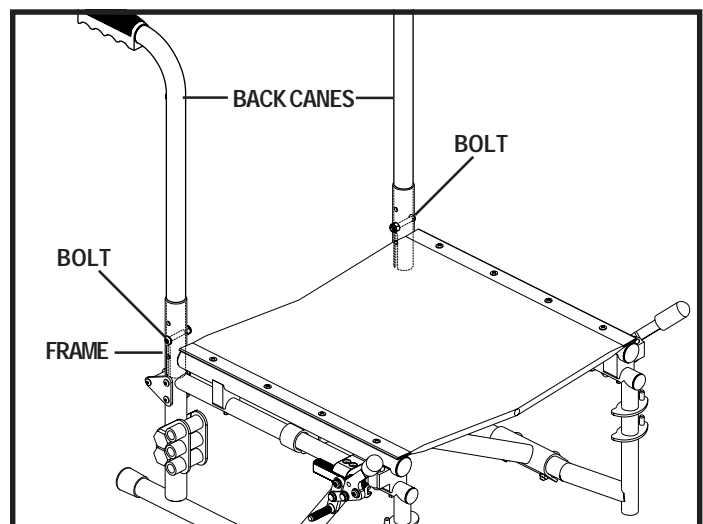

Figure 20. Seatback Height Adjustment

IV. COMFORT ADJUSTMENTS

Seatback Angle Adjustment (Optional)

Your wheelchair may be equipped with angle adjustable back canes that allow you to adjust the seatback to one of five different angles. The angle adjustment range is 85°-105° in 5° increments. See figure 21.

To adjust the seatback angle:

1. Remove the top screw and nut from the back cane and loosen the lower screw. See figure 21.
2. Rotate the eccentric washer to the appropriate position that represents the desired angle. See figure 21.
3. Reinstall the hardware to its original position from step 1.

Flip-back Armrests

The armrests can be flipped up to aid in transfers or transporting your wheelchair.

To flip up the armrest:

1. Squeeze the armrest latch to release the armrest. See figure 22.
2. Flip the armrest back.
3. Repeat for the other side if necessary.

Armrest Height Adjustment

You can adjust the armrest height 7 in. (17.78 cm) in 1-in. (2.54-cm) increments.

To adjust the armrest height:

1. Pull back and hold the release pin located on the armrest. See figure 23.
2. Move the armrest up or down to the desired position.
3. Release the pin.
4. Make sure the armrest locks into place.
5. Repeat for the other side if necessary.

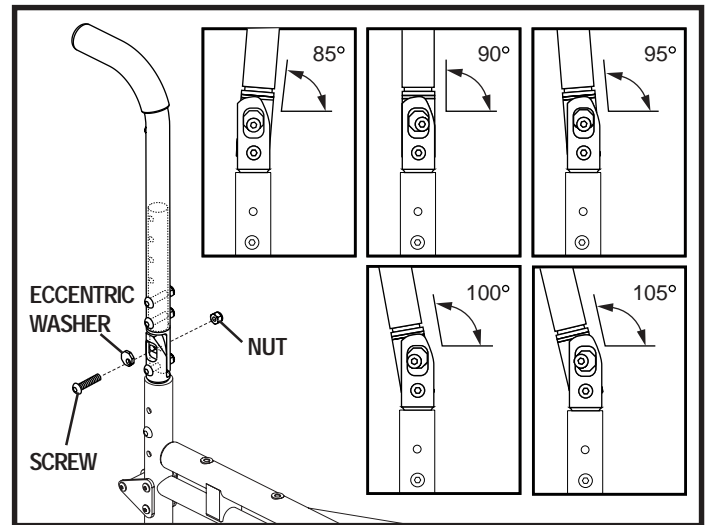

Figure 21. Seatback Angle Adjustment

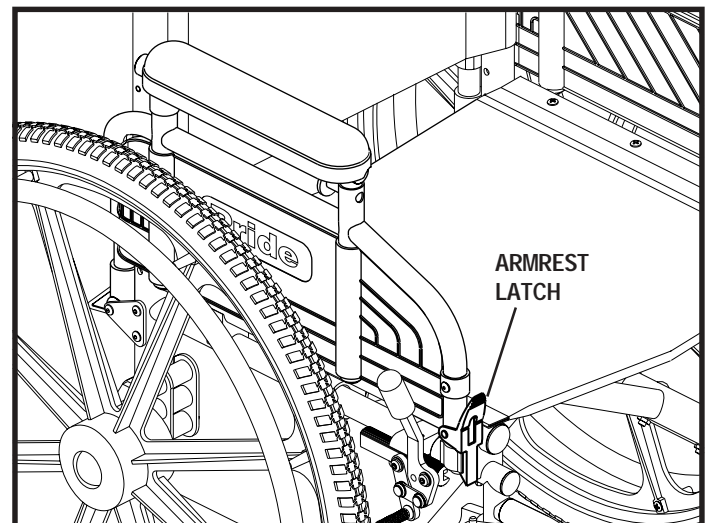

Figure 22. Flip-back Armrests

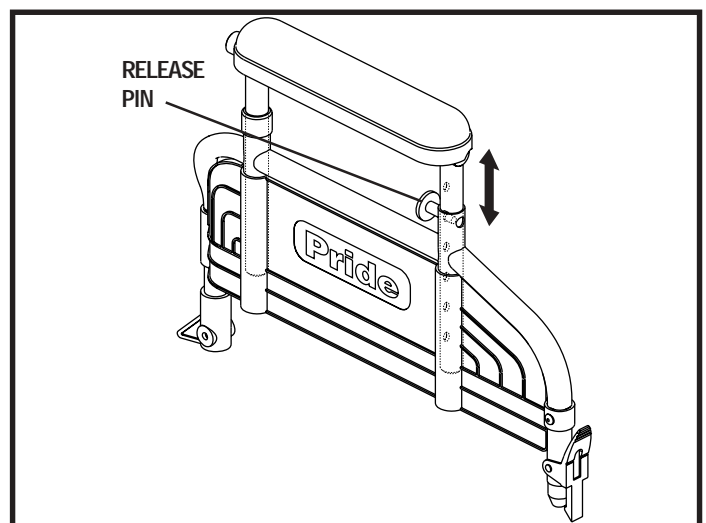

Figure 23. Armrest Height Adjustment

IV. COMFORT ADJUSTMENTS

Seat Angle (Dump)

The position of the caster wheels affects the angle (dump) of the seat. By changing the location of the caster wheel on the fork, you change the seat angle. See figure 24.

NOTE: *You can also adjust the seat angle by raising or lowering the drive wheel. See “Drive Wheel Position.”*

To change the seat angle:

1. Remove the hardware that fastens the caster wheel to the caster fork.
2. Reposition the caster wheel on the caster fork.
3. Reinstall the hardware that fastens the caster wheel to the caster fork.
4. Repeat the procedure for the other side, making sure both caster wheels are adjusted to the same position.



WARNING! Changing the seat angle may adversely affect stability and cause the wheelchair to tip over.

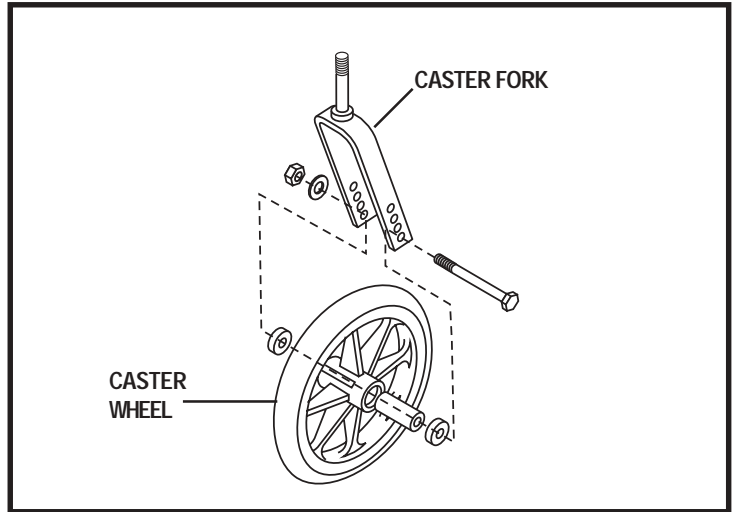

Figure 24. Caster Wheel Position

IV. COMFORT ADJUSTMENTS

Caster Angle

When you change the seat angle, you must also change the caster angle so that the caster barrels remain at a 90° angle to the ground. There are three possible caster angles. See figure 26. If the front of the seat is higher than the rear, the caster assembly should be in position 1. If there is little or no seat dump (i.e., the seat is parallel to the ground), the caster assembly should be in position 2. If the rear of the seat is higher than the front, the caster assembly should be in position 3.

NOTE: *There are two bolts that fasten the caster wheel assembly to the frame. The bolt shafts are offset to the heads. The bolt shafts must be positioned either fore or aft relative to the holes.*

To change the caster angle:

1. Remove the bolts that fasten the caster wheel assembly to the frame.
2. Reposition the bolts according to the table in figure 25.
3. Tighten the bolts.

NOTE: *Make sure that both casters are adjusted to the same angle.*

Caster Position	Top Bolt Position	Bottom Bolt Position	Caster Wheel Angle
1	Fore	Aft	95
2	Fore	Fore	90
3	Aft	Fore	85

Figure 25. Caster Angles

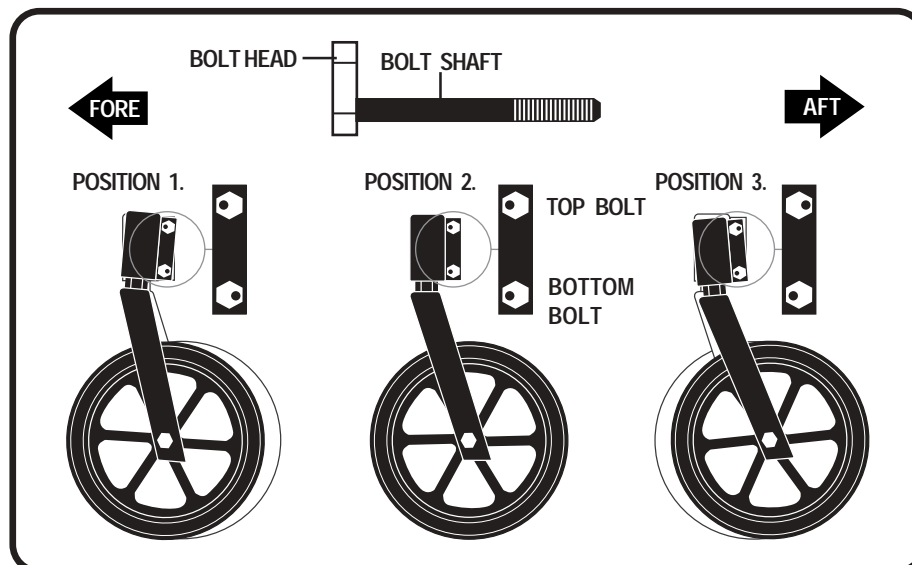

Figure 26. Caster Angle Adjustment

CARE AND MAINTENANCE

Your Stylus requires routine maintenance checks. You can perform some of these checks, but others require assistance from your authorized Pride Provider. Preventive maintenance is very important. If you follow the maintenance checks in this section as scheduled, you can help ensure that your wheelchair gives you years of trouble-free operation. If you have any doubt as to your wheelchair's care or operation, contact your authorized Pride Provider.



WARNING! Do not service the wheelchair when the seat is occupied.

Your wheelchair is susceptible to damage from the elements. Avoid damp areas of any kind.



WARNING! Direct or prolonged exposure to water or dampness could cause the wheelchair to malfunction mechanically. Water can cause the chair's frame to rust. Wheelchairs should be examined periodically for signs of corrosion caused by water exposure, bodily fluids exposure, or incontinence. Damaged components should be replaced or treated immediately.

Should your wheelchair come in contact with water:

1. Dry your wheelchair as thoroughly as possible with a towel.
2. Allow your wheelchair to sit in a warm, dry place for 12 hours to allow unseen water to evaporate.
3. If any inconsistencies are found, take your wheelchair to your authorized Pride Provider. Wheelchairs that are frequently exposed to sources of water, such as incontinence, should be inspected often for corrosion.

Temperature

- Some of the parts of your wheelchair are susceptible to extreme changes in temperature. Always keep your wheelchair between the temperatures of 18° F (-8° C) and 122° F (50° C).

General Guidelines

- Avoid prolonged exposure of your wheelchair to extreme conditions, such as heat, cold, or moisture.
- Make sure the pneumatic tires are inflated to **65 psi (4.5 bar)** if equipped with pneumatic tires.



WARNING! Make sure your tires are inflated to 65 psi (4.5 bar). Do not underinflate or overinflate your tires. Low pressure may result in loss of control, and overinflated tires may burst. Overinflating tires can cause them to explode.

WARNING! Do not use a high pressure hose to inflate your tires.

- Use a rubber conditioner on the tire sidewalls to help preserve them.



WARNING! Never use a rubber conditioner on the tread area of the tires; doing so may make the tires slippery and cause your wheelchair to skid.

- All wheel bearings are prelubricated and sealed. They require no subsequent lubrication.

Daily Checks

- Check for loose or missing screws, nuts, and bolts. Replace or tighten them as necessary.
- Check the tires. Look for uneven wear, holes, or tire/rim separation. If they look excessively worn, then have them replaced.
- Visually inspect pneumatic tires for punctures.
- Confirm correct air pressure as marked on the side of the tire.
- Check for flat spots on solid tires. Flat spots could adversely affect stability.

V. CARE AND MAINTENANCE

- Check the handrims. Make sure that they are fastened securely to the wheels.
- Check the manual park brakes. Make sure they work properly. If they do not, instructions on how to adjust them are provided in this manual.



WARNING! The manual park brakes are designed to keep your chair stationary while you are parked. They are not designed to stop the wheelchair during driving. Do not use either of the manual park brakes to stop the wheelchair while driving it. This can cause your wheelchair to become unstable and tip.

Weekly Checks

- Check for proper tire inflation. There should be **65 psi (4.5 bar)** in each tire. If a tire does not hold air, see your authorized Pride Provider for replacement of the tube.

Monthly Checks

- Check for drive tire wear. See your authorized Pride Provider for repair.
- Check the caster wheels for wear. Replace them as necessary.
- Check the caster forks for damage or fluttering which indicates that they may need to be adjusted or have the bearings replaced. See your authorized Pride Provider for repair.
- Keep your wheelchair clean and free of foreign material, such as mud, dirt, hair, food, drink, etc.

Yearly Checks

Take your wheelchair to your authorized Pride Provider for yearly maintenance, especially if you use your wheelchair on a daily basis. This helps ensure that your wheelchair is functioning properly and helps prevent future complications.

Storage

Your wheelchair should be stored in a dry place, free from temperature extremes.



WARNING! If you fail to store the unit properly, the frame can rust.

You may wish to place several boards under the frame of your wheelchair to raise it off of the ground during periods of prolonged storage. This takes the weight off the tires and reduces the possibility of flat spots developing on the areas of the tires contacting the ground.

Disposal of Your Wheelchair

Your wheelchair must be disposed of according to applicable local and national statutory regulations. Contact your local waste disposal agency or authorized Pride Provider for information on proper disposal of wheelchair packaging, metal frame components, and plastic components.

Cleaning and Disinfection

- Use a damp cloth and mild, non-abrasive cleanser to clean the plastic and metal parts of your wheelchair. Avoid using products that may scratch the surface of your wheelchair.
- If necessary, clean your product with an approved disinfectant. Make sure the disinfectant is safe for use on your product before application.



WARNING! Follow all safety instructions for the proper use of the disinfectant and/or cleaning agent before applying it to your product. Failure to comply may result in skin irritation or premature deterioration of upholstery and/or wheelchair finishes.

WARNING! Never hose off your wheelchair or place it in direct contact with water. Your wheelchair has a painted finish that allows it to be easily wiped clean with a damp cloth.

V. CARE AND MAINTENANCE



WARNING! Never use any chemicals to clean a vinyl seat, as they may cause the seat to become slippery or dry out and crack. Use soapy water and dry the seat thoroughly.

Wheel Replacement

If you have pneumatic tires and you have a flat tire, you can replace the tube. If your wheelchair is equipped with a solid tire insert, then you must replace the entire wheel assembly. Replacement tires, tubes, and wheel assemblies are readily available through your authorized Pride Provider.



WARNING! The wheels on your wheelchair should only be serviced or replaced by an authorized Pride Provider or a qualified technician.

WARNING! When changing a tire, remove the drive wheel. If any further disassembly is required, deflate the tire completely or it may explode.

To replace a pneumatic tire tube:

1. Remove the drive wheel from the frame. See figure 11 or 12.
2. Make sure that the tube is deflated completely.
3. Use several tire levers to pry the tire from the rim. Tire levers are available from a bicycle shop.
4. Remove the old tube.
5. Inflate the new tube with enough air so that it just starts to take shape, about **5 psi (0.34 bar)**.
6. Insert the tube into the tire.
7. Use the tire levers to secure the tire back onto the rim.
8. Inflate the tire to the pressure recommended on the sidewall **65 psi (4.5 bar)**. Always use a regulated air source.
9. Reinstall the drive wheel to the frame. Make sure that the wheel axle is snapped securely into the frame bracket.

Manual Park Brakes

After several months of use, you may find it necessary to adjust the park brakes so that they lock securely when engaged. You also may need to adjust them after changing the drive wheel position.



WARNING! If your wheelchair is equipped with pneumatic tires, make sure they are inflated to the pressure recommended on the sidewall of the tire (**65 psi/4.5 bar**).

To adjust each manual park brake:

1. Disengage the park brake. See figure 6 or 7. The park brake should be 1/4 in. (0.64 cm) away from the tire for both pneumatic and solid tires.
2. Loosen the hardware that fastens the park brake to the frame. See figure 27.
3. Reposition the park brake so that it is 1/4 in. (0.64 cm) away from the tire and perpendicular to the plane of the tire.
4. Tighten the hardware that fastens the park brake to the frame.
5. Engage the park brake and note the position of the blade.
6. Reposition the park brake if necessary.
7. Repeat the procedure for the other side.

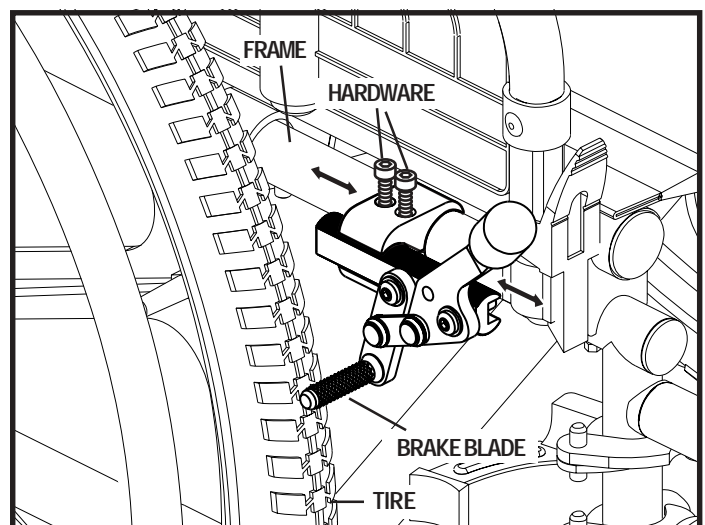

Figure 27. Manual Park Brake Adjustment

Seat Tension

After a period of use, you may find it necessary to adjust the seat tension.

To adjust the seat tension:

1. Loosen the screws that attach the seat to the side rail on the left side (side with hook and loop fastener). See figure 28.
2. Unfasten the hook and loop fastener.
3. Grab the bottom flap and pull the seat tight.
4. Fasten the hook and loop fastener.
5. Tighten the screws. Make sure that the plastic washers are on top of the fabric.

When to See Your Authorized Pride Provider for Service

The following symptoms could indicate a serious problem with your wheelchair. If necessary, contact your authorized Pride Provider. When calling, have the model number, serial number, and nature of the problem.

- Uneven wear on any of the tires
- Bent or broken wheel assemblies

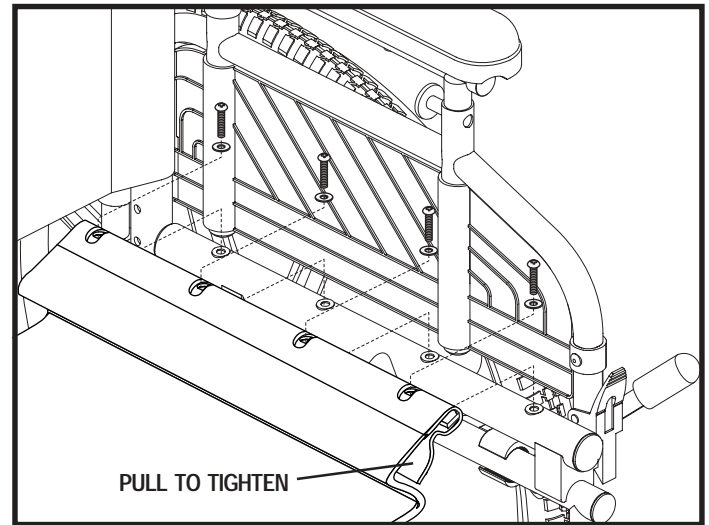

Figure 28. Seat Tension Adjustment

V I . W A R R A N T Y

Pride warrants this product, so far as the same is of its own manufacture, to be free of defects in material and workmanship, when used by the purchaser under normal conditions, for (1) year after purchase. The side frames and cross-frames are warranted for the life of the product to the original purchaser.

The warranties herein specified shall not apply if the failure of any component of this product to satisfy such warranty is due to accident, neglect, misuse, improper transportation arranged by the purchaser or its agent, or causes other than ordinary use including operation contrary to Pride's operating instructions or if any person other than Pride's authorized personnel shall modify, adjust, or repair such product or perform any related service on it.

It must be understood that the purchaser assumes full responsibility for the overall safe operation in the environment for which the product is intended to function.

APPENDIX I: SPECIFICATIONS

STYLUS SPECIFICATIONS	
Seat Dimensions:	16 in. x 16 in., 18 in x 16 in., 18 in. x 18 in., 20 in. x 16 in., 20 in. x 18 in.
Back Height:	15 - 17 in., 17-19 in.
Seat Upholstery:	Adjustable tension
Seat-to-Floor Height:	See figure 13.
Caster Wheels:	5 in. (12.70 cm), 6 in. (15.24 cm), or 8 in. (20.32 cm)
Axle Mount:	6-position
Caster Fork:	4-position axle
Maximum Safe Slope:	5° (8.7%)
Turning Radius: ¹	See figure 29.
Overall Size: ¹	Length: See figure 29. Width: See figure 29.
Weight Capacity:	250 lbs. (113.4 kg)
Component Weights:	Base: 29 lbs. (13.1 kg) without front riggings
Armrests:	Flip-back, desk-length; Height-adjustable, desk or full length
Front Rigging:	Swing-away leg rests, Elevating leg rests
Brakes:	Push-to-lock, adjustable; Pull-to-lock
Frame Finish:	Silver Vein
Accessories:	Anti-tip wheels; oxygen tank holder; wheel lock extension

¹ Due to manufacturing tolerances and continued product improvement, this specification can be subject to a variance of (+ or -) 3%.

NOTE: All specifications subject to change without notice.

APPENDIX I: SPECIFICATIONS

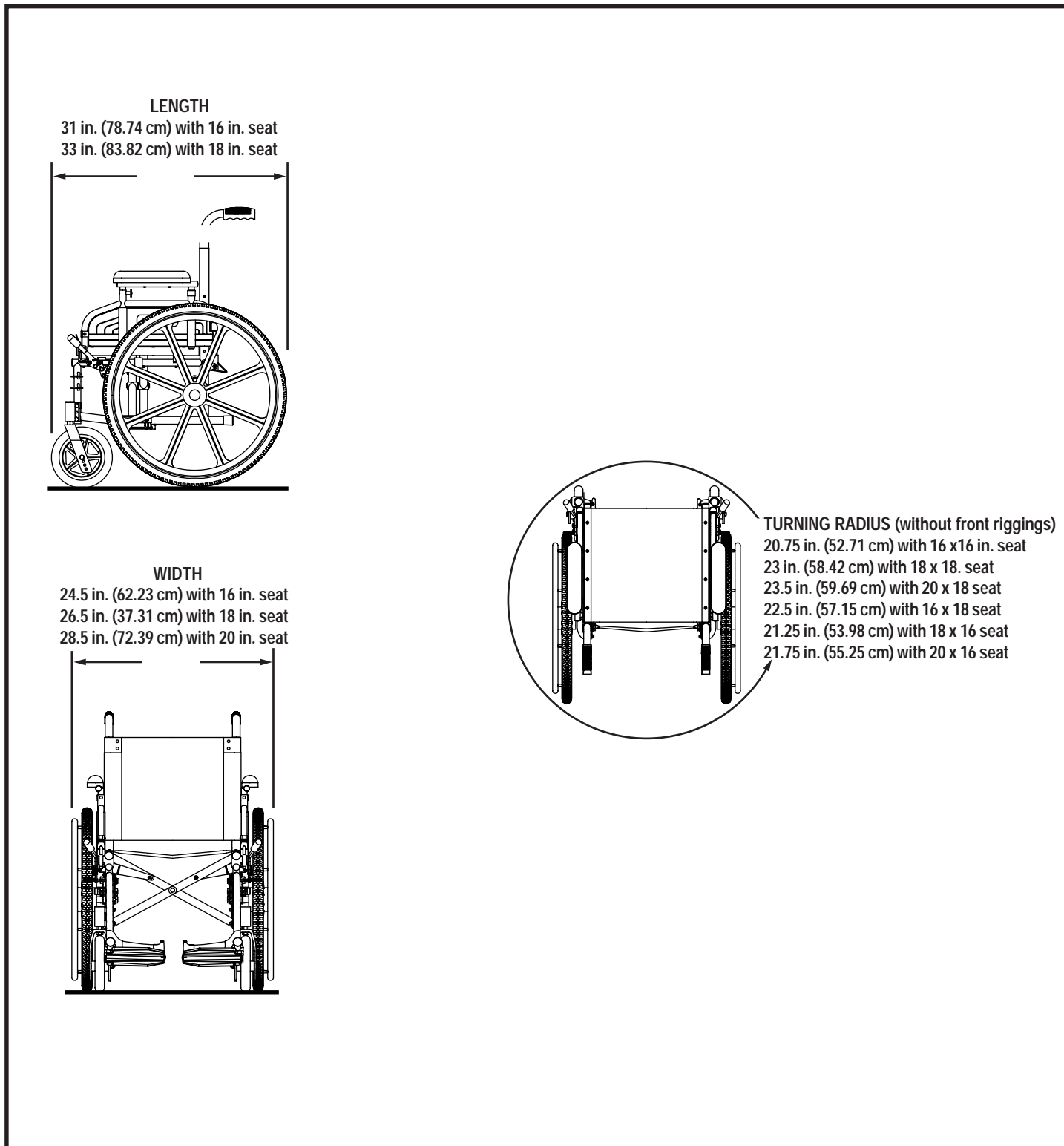

Figure 29. Stylus Specifications

Quality Control - Stylus

Inclusion of all Parts

Fit and Finish

Performance



Pride keeps a more detailed report on file at the factory.

Date Inspected

Inspector

* I NFMANU2121 *

Product Serial #