

INSTRUCTION MANUAL



POWER STAND UP WHEELCHAIR

KARMAN HEALTHCARE INC.

City of industry, CA 91748

800-8052762

www.karmanhealthcare.com

Table of Contents

P.3 XO-202: Parts Explanation

Chapter 1. SAFETY TIPS

- 1-1. Standing
- 1-2. Important symbols found on the vehicle
- 1-3. Safety Information on Driving and Freewheel Mode
- 1-4. Rear Wheels
- 1-5. Armrests
- 1-6. Power Drive Attachments
- 1-7. Modifications

Chapter 2.

UNPACKING AND PREPARING THE STAND UP

WHEELCHAIR EX SERIES STAND UP WHEELCHAIR FOR USE

- 2-1. The original package and accessories.
- 2-2. Unfolding the stand up wheelchair

Chapter 3. ADJUSTMENT

- 3-1. Adjusting the seat depth
- 3-2. Adjusting the backrest height
- 3-3. Adjusting the Footrest height
- 3-4. Adjusting the Footrest Angle
- 3-5. The knee support and safety belt and chest belt
- 3-6. Adjusting the Armrest height
- 3-7. The heel strap
- 3-8. Gas spring
- 3-9. The seat cushion

Chapter 4. DRIVING

- 4-1. **Before Driving for the First Time**
- 4-2. Taking Obstacles
- 4-3. Driving Up and Down Gradients
- 4-4. Free Wheeling

Chapter 5. OPERATION THE STANDING AND SITTING

Chapter 6. CONTROL SYSTEM

- 6-1. The SHARK II Remote
- 6-2. Battery and control box connection
- 6-3. Battery charge

Chapter 7. MAINTENANCE & WARRANTIES

XO-202 Series

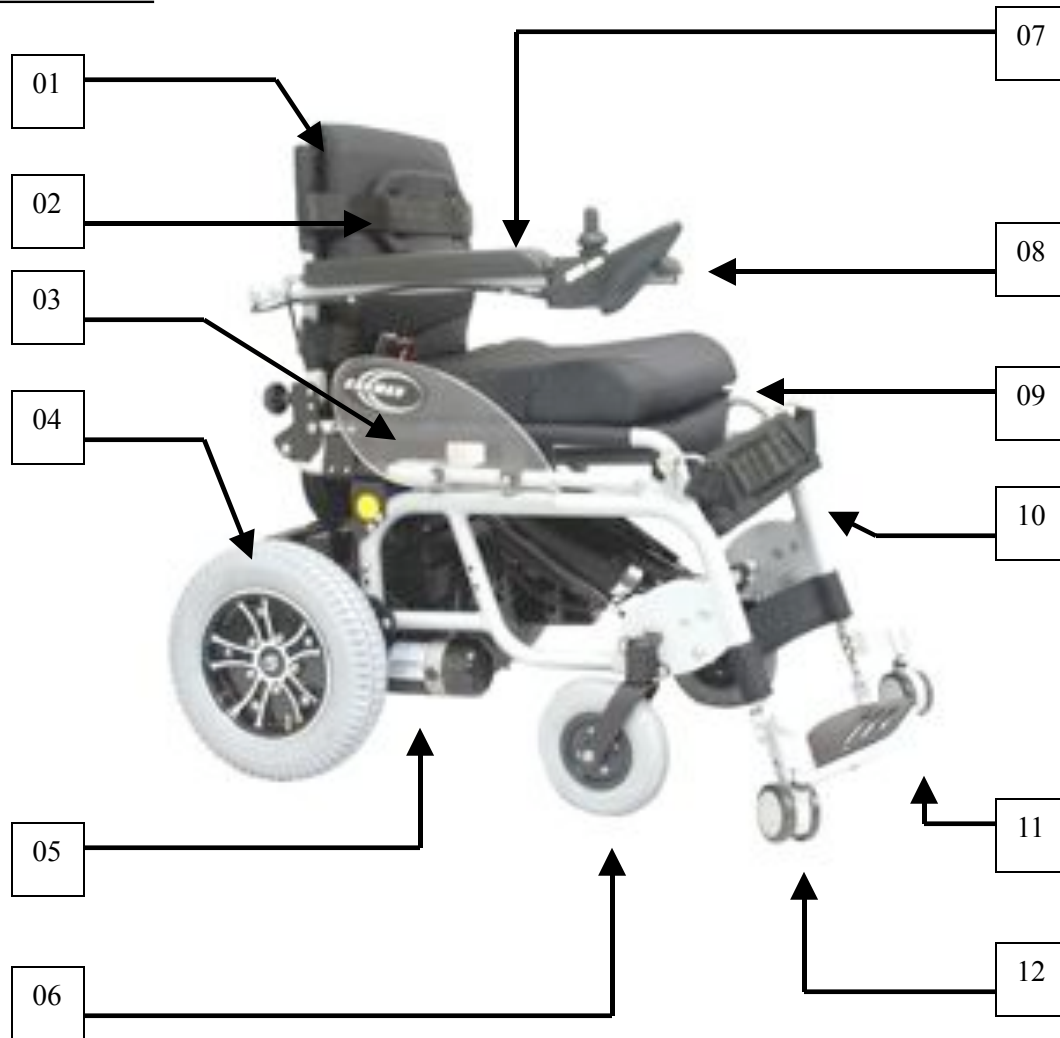

01	Backrest	07	Armrest
02	Chest belt	08	Controller Chest belt
03	Side Panel	09	Seat Rest
04	Rear Wheel	10	Knee Support Set
05	Motor/Differential Gear	11	Footrest
06	Front Wheel	12	Stand Up Casters

Chapter 1. SAFETY TIPS

Powered Chair Electromagnetic Interference (EMI)

WARNINGS

The following warning listed below should reduce the chance of unintended brake release or Powerchair movement, which could result in serious injury.

1. Do not operate hand-held transceivers (transmitter-receivers), such as citizens band (CB) radios, or turn ON personal communication devices, such as cellular phones, while the Powerchair is turned ON.
2. Be aware of nearby transmitters, such as radio or TV stations, and try to avoid coming close to them.
3. In unintended movement or brake release occurs, turn the Powerchair OFF as soon as it is safe.
4. Be aware that adding accessories or components, or modifying the Powerchair may make it more susceptible to EMI.

1-1. Standing

Attention:





- Standing up stresses your body in ways you may not be used to. You should consult your doctor or physical therapist before using the stand-up wheelchair.
- Before using the stand up wheelchair you should suppose to be familiar with the operation and the function.
- Use only standard household and hard even ground. Not use in the ground of dripping wet.
- In case of staircase, the stand up wheelchair must be carried by 2 persons.
- When rides or leaves the stand up wheelchair, should not put the foot on the footplate, to avoid the dangers.
- Before standing up it is absolutely vital that the knee support, safety belt and Chest belt are fixed correctly.

WARNING:

Maximum weight limit should not exceed

XO-202: 250 lbs.

1-2. Important symbols found on the vehicle

	<p>DO NOT DRIVE OVER UNEVEN GROUND!</p> <p>Danger of tipping over!</p>
	<p>DO NOT LEAN OUT OF THE RAISED VERTICALIZER!</p> <p>Danger of tipping over!</p>
	<p>NEVER DRIVE ON ASCENDING OR DOWNWARD SLOPES WHEN THE VERTICALIZER IS RAISED!</p> <p>Danger of tipping over!</p>
	<p>NEVER REACH INTO THE MOVING APPARATUS OF THE RAISED VERTICALIZER!</p> <p>Danger of crushing!</p>

1-3 Safety Information on Driving and Freewheel Mode

Danger of injury if the wheelchair tips over

- Only ever negotiate gradients up to the maximum tilt-resistant gradient and only with the backrest and seat tilt in an upright position.
- Only ever drive downhill at a maximum of 2/3 of the top speed! Avoid abrupt braking or acceleration on gradients.
- If at all possible, avoid driving on slippery surface (such as gravel) where there is a danger of you losing control over the vehicle, especially on a gradient! If driving on such a surface is inevitable, then always drive slower and with the utmost caution.

- Never attempt to overcome an obstacle when on an uphill or downhill gradient!
- Never attempt to drive up or down a flight of steps with your wheelchair!
- Always approach straight on! Ensure that the front wheels and rear wheels move over the obstacle in one stroke! Do not stop halfway! Do not exceed the maximum obstacle height!
- Avoid shifting your center of gravity as well as abrupt joystick movements and changes of direction when the wheelchair is in motion!
- Never use the wheelchair to transport more than one person!
- Do not exceed the maximum permissible load!
- Note that the wheelchair will break or accelerate if you change the Driving Mode while the wheelchair is in motion!

1-4. Rear Wheels

CURBS, INCLINES AND RAMPS

Always practice with your Healthcare professional or attendant before attempting to negotiate curbs, inclines or ramps alone. It is important for you to develop a safe technique that is suitable to your abilities.

WARNING:

Doing a "wheelie" (tilting the wheelchair Backward to its balance point) can be dangerous.

Do not attempt this maneuver without an attendant.

1-5. Armrests

Flip-back Armrests

Never lift the wheelchair by the Flip-back armrests. These parts are detachable and lifting the wheelchair by them may cause damage to the chair or injury to the user.

1-6. Power Drive Attachments

Power stand up wheelchair does not advocate the use of power drive attachments on any XO-202 series wheelchair. Use of a power drive attachment on XO-202 series wheelchair alters its intended use. Installation of a power drive attachment is considered an alteration to the frame and voids the warranty.

1-7. Modifications

Marking any unauthorized modifications or using parts not supplied by [\(Karman Healthcare Inc.\)](#) may change the wheelchair structure and create an unsafe condition voiding the warranty.



This product has been supplied from an environmentally aware manufacturer that complies with the Waste Electrical Equipment (WEEE) Directive 2002/96/CE. Please be environmentally responsible and recycle this product at the end of its life through your local recycling facility.

This product may contain substances that could be harmful to the environment if disposed of into a landfill.

Chapter 2. UNPACKING AND PREPARING THE POWER STAND UP WHEELCHAIR XO-202 SERIES FOR USE

2-1. The Original Package And Accessories

The Following Components:

- Power Stand up wheelchair wheel strap & chest belt
- Knee Support
- Charger (USA users check charger switch is set to 115VAC)
- Oil pot
- User manual and tool
- Options as ordered

2-2. Unfolding the Stand up Wheelchair

Please Process as Follows:

- Remove any transport straps or transport guards.
- Grasp the wheelchair at the backrest and pull backward and push downward up to stop.
(Fig-1 & 2)
- Tighten the knob of left and right. (Fig-3)
- Press the flip-back Armrest forward.
- Connect the DC power line to power socket of battery.

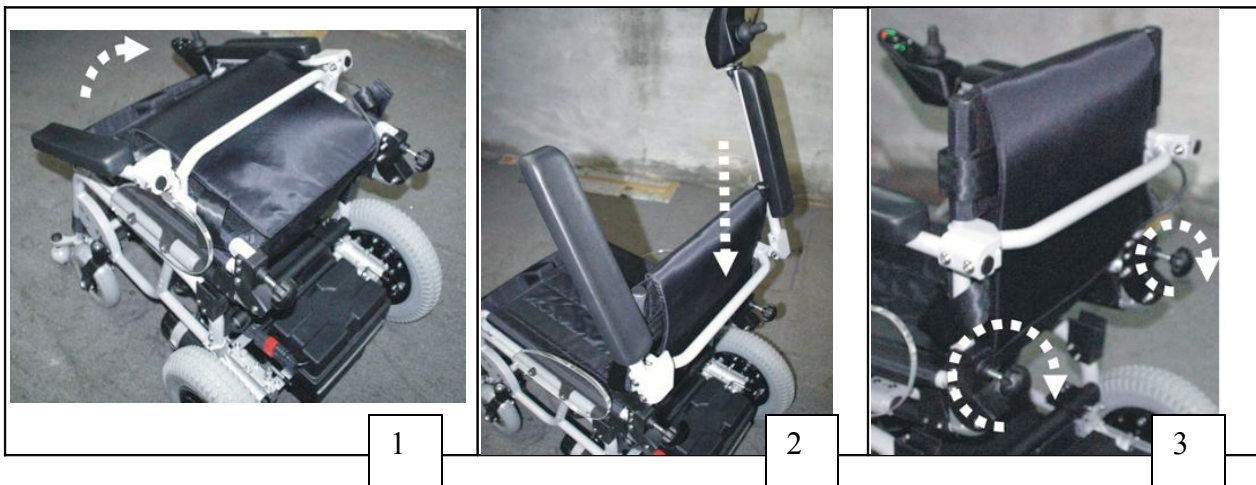

Chapter 3. ADJUSTMENT

Should you require adjustments and alterations to the mechanism of the wheelchair, or any maintenance work, please contact qualified technicians.

3-1. Adjusting the Seat Depth

- (1) Pull upward (push forward) the handle controller let the wheelchair frame rise over the rear wheel.
- (2) After loosening the left (right) both side screws the seat depth can be adjusted using the different holes at 1" distance. (Fig- 4 ~ 6)
- (3) Retighten the left (right) both side screws. (Fig- 7 & 8)

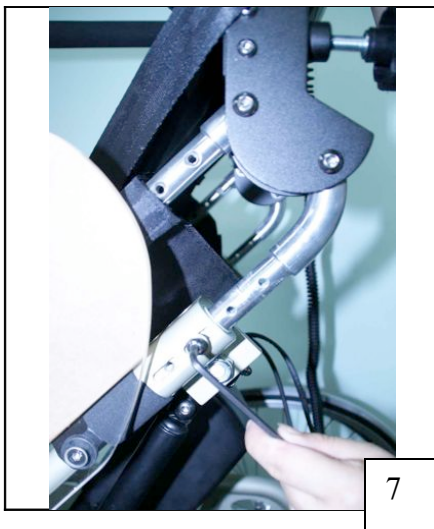
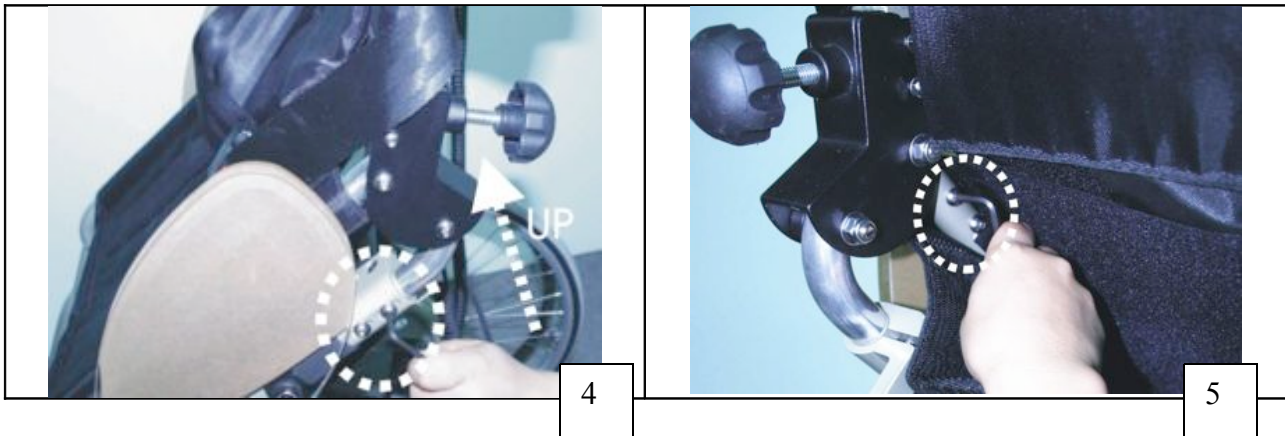

3-2. Adjusting the Backrest Height (Fig-9 ~12)

- (1) Remove the backrest padded.
- (2) After opening the screws, the backrest height can be adjusted using the different concave at 2cm distance.
- (3) Retighten the screws.

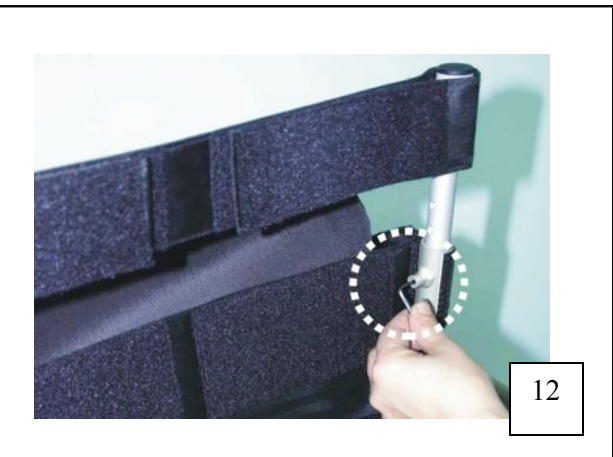
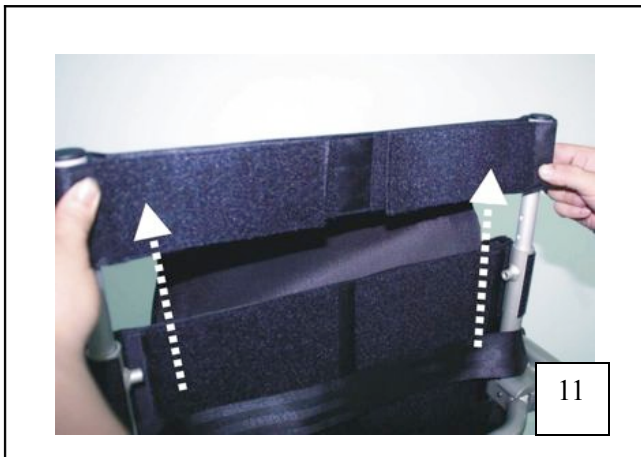
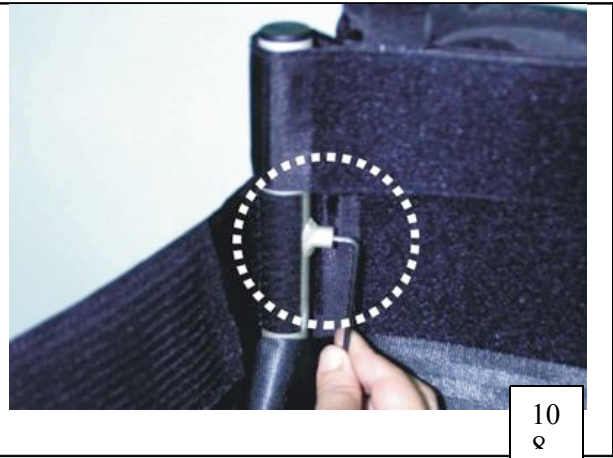

3-3. Adjusting the Footrest Height

The height of the footrest is adjustable and should be altered in line with your body proportions to guarantee the best standing position possible. Footrest adjustment should also take account of your choice of seat cushion. (Fig-13 ~ 16)



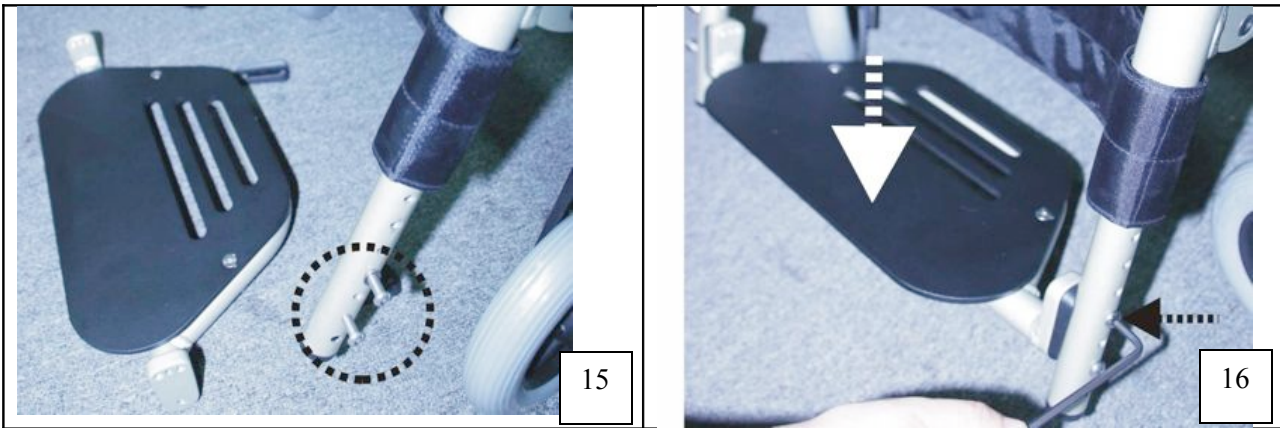

- After loosening the screws the Footrest height can be adjusted using the different holes at 1.8cm distance.
- Retighten the screws. (not too tight)

3-4. Adjusting the Footrest Angle

- After release the screws the footplate angle can be adjusted using the different hole at 10° incline angle. (Fig-17 & 18)
- Retighten the screws. (Fig-19)

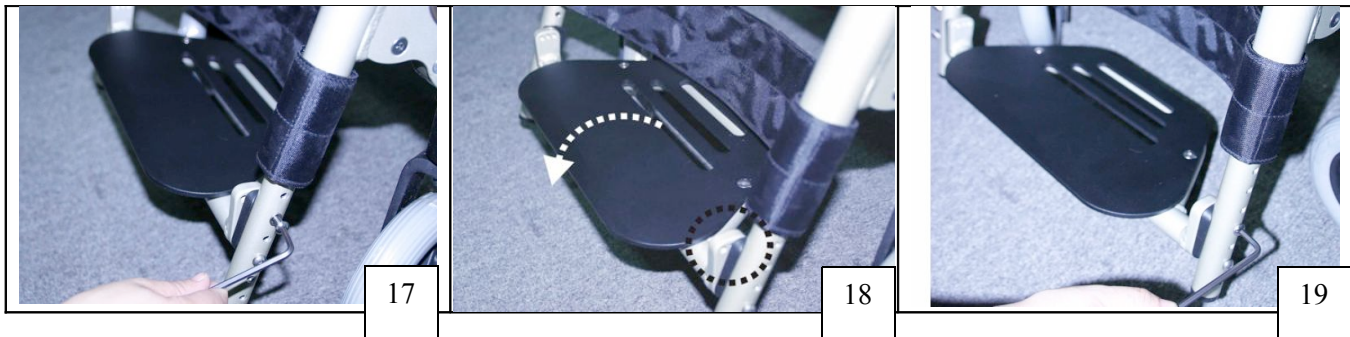

3-5. The Knee Support and Safety Belt and Chest Belt

The most important safety features of the stand-up wheelchairs are the knee support & safety belt and chest belt. It is absolutely essential that these be correctly in place before you attempt to stand up.

3-5-1. The knee support

The knee support holds the knees in an extended posture and prevents you slipping out the power wheelchair while standing up.

Attach the two triangular form of the knee lock support to the double-head screws on either side of the wheelchair. (Fig-20)



20

Center the knee support in front of each knee using the Velour fasteners, then pull it until it is sitting firmly in place, just below (not right on) the knee cap and not too tight. (Fig-21)



21

3-5-2. The safety belt (Fig-22)

- The safety belt holds the waist in place.
- Make sure that the safety belt is secure on the backrest of Velcro faster.
- Close the catch on the safety belt and pull it and not too tight.
- To release the safety belt. Simply press the red button in the center of the catch.
- To slacken, hold the catch at a right angle to the belt and pull.



22

3-5-3. Adjusting the chest belt (Fig-23 ~ 25)

- Make sure that the chest belt is secure on the backrest of Velcro fastening.
- The chest belt is holding the upper body (chest in place).

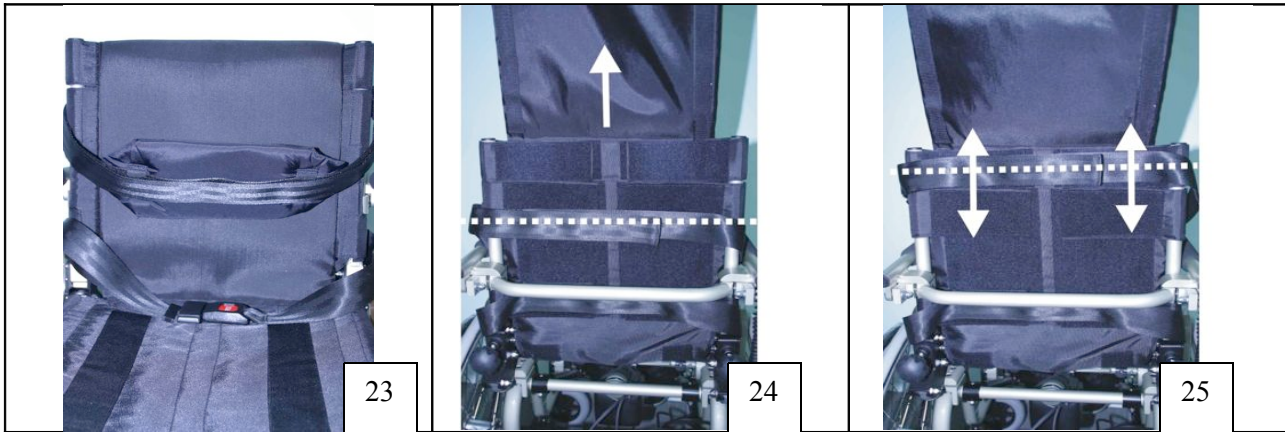

3-6. Adjusting the Armrest Height

- (1) Release the left (right) screws up to the clamp can be removed to suit position. (height 7"~10") (Fig-26 & 27)
- (2) Retighten the screws of clamp.

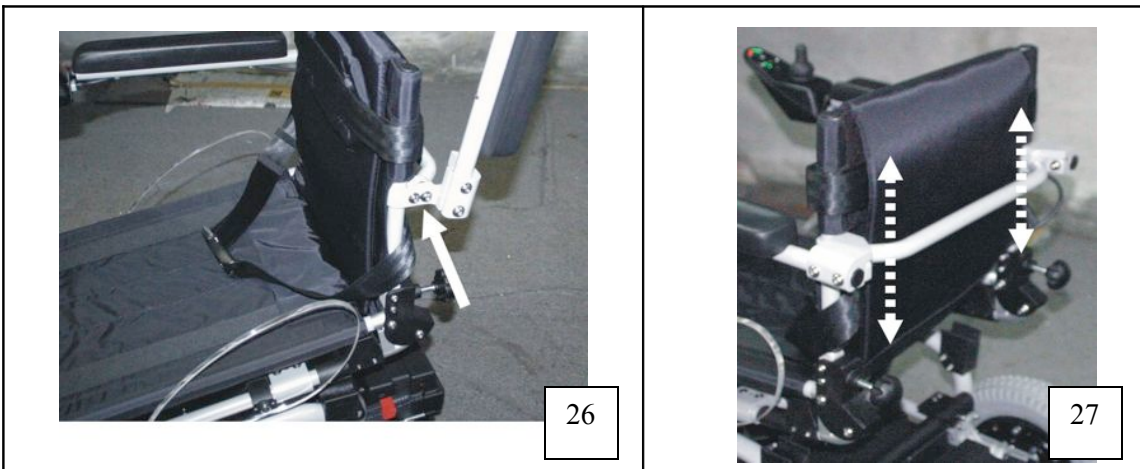

3-7. The Heels Strap (Fig-28)

The purpose of the heel strap is to prevent the legs and feet slipping backwards. It is fitted behind the heels or higher. By making use of the Velcro fastening it is possible to alter the length of the strap and thus to ensure the ideal position for the feet on the footrest. Ideal positioning of the feet is vital in ensuring a good standing position.

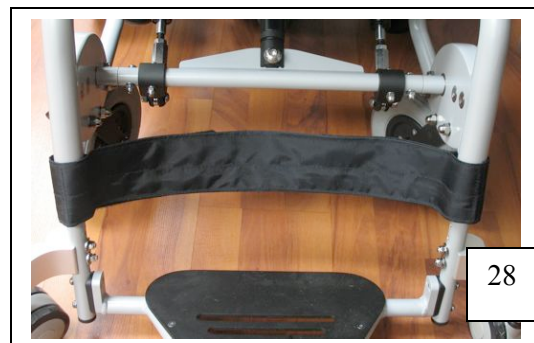

3-8. Gas Spring

The gas springs are specially designed to help hold your body weight in the balance.

NOTE: Contents under pressure. Do not take apart puncture apply heat or fire.

3-9. The Seat Cushion

The Velcro fasteners prevent the cushion from slipping out of place even when you are standing up. The height of the footrest should be adjusted to take into account the height of a given seat cushion.

Once the knee support, safety belt and chest belt are fitted correctly you are ready to stand up.

Chapter4. DRIVING

4-1 Before Driving for the First Time

Before you take your first trip, you should familiarize yourself well with the operation of the vehicle and with all operating elements. Take your time to test all functions and driving modes.

Attention:

- You are within easy reach of all operating controls.
- The battery charge is sufficient for the distance intended to be covered.

4-2 Taking Obstacles

Your electric wheelchair is able to overcome obstacles and curbstones to a maximum height of 4cm.

WARNING:

- Never approach obstacles at an angle!
- Put your backrest into an upright position before climbing an obstacle!
- Never drive over obstacles with an erected vertical. Always lower the vertical completely prior to this.

4-3 Driving up and down gradients

Your electric wheelchair has a maximum tilt-resistant climbing ability of 17.6%.

WARNING:

- Only ever drive downhill at a maximum of 1/2 of the top speed.
- Avoid sudden changes of direction or abrupt braking when driving on slopes.
- Always return the backrest of your seat or the seat tilt to an upright position before ascending slopes. We recommend that you position the seat backrest or the seat tilt slightly to the rear before descending slopes.
- If the lifter is raised drive mode is only used for positioning and not for regular drive operation. Lower the lifter before ascending a slope.
- Never attempt to ascend or descend a slope on slippery surfaces or where there is a danger of skidding.
- Avoid trying to get out of the vehicle on an incline or a gradient.
- Always drive straight in the direction the road or path you are on goes, rather than attempting to zigzag.

- Never attempt to turn around on an incline or a slope.

DANGER:

- When the vertical is raised drive operation only serves positioning and not normal driving.
- Never driver over uneven ground, on an upward or downward slope obstacles when the vertical.

4-4 Free Wheeling:

Because the motors are designed to engage the electromagnetic brakes when the vehicle is not in use or when the power is OFF. There is also a manual feature that allows them to “free-wheel”. Free- wheeling is accomplished by pulling the free- wheeling levers to the free-wheeling position. (Fig29)

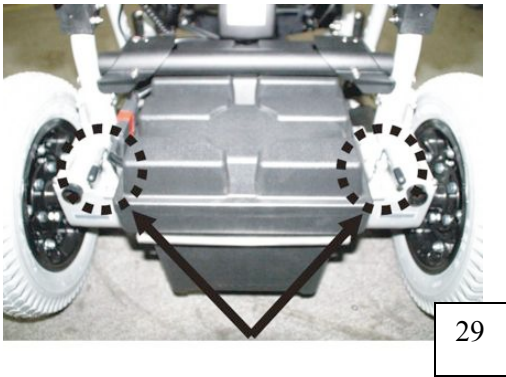

WARNING:

- Never free-wheel your power wheelchair on a slope.
- Never free-wheel the motors while operating your vehicle.
- Always remember to engage the motors before turning the power back ON.

Chapter 5. OPERATION THE STANDING AND SITTING

1. First, adjusting and fixed the knee support to suit position and make sure the two triangular form of knee support lock to the double-head screws of frame. (Fig-30 & 31)

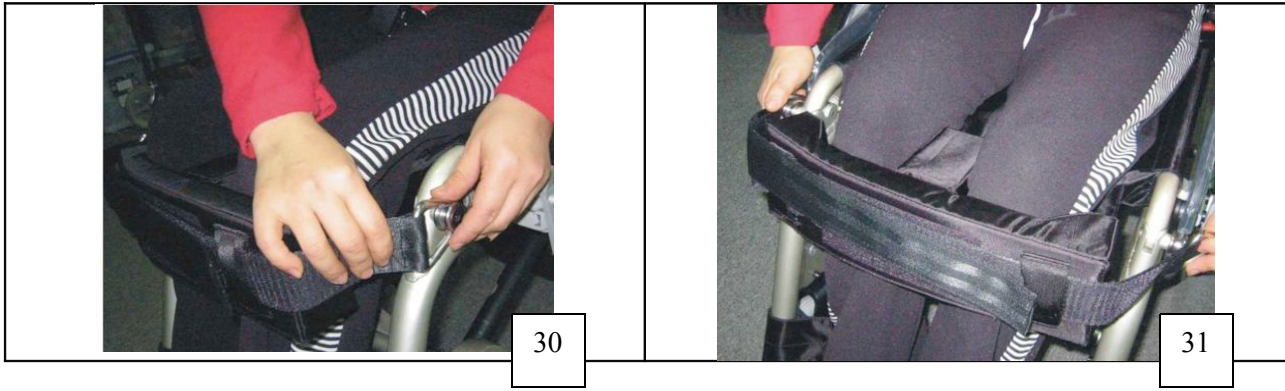

2. Fixed the safety belt. (Fig-32)
3. Fixed the chest belt. (Fig-33)

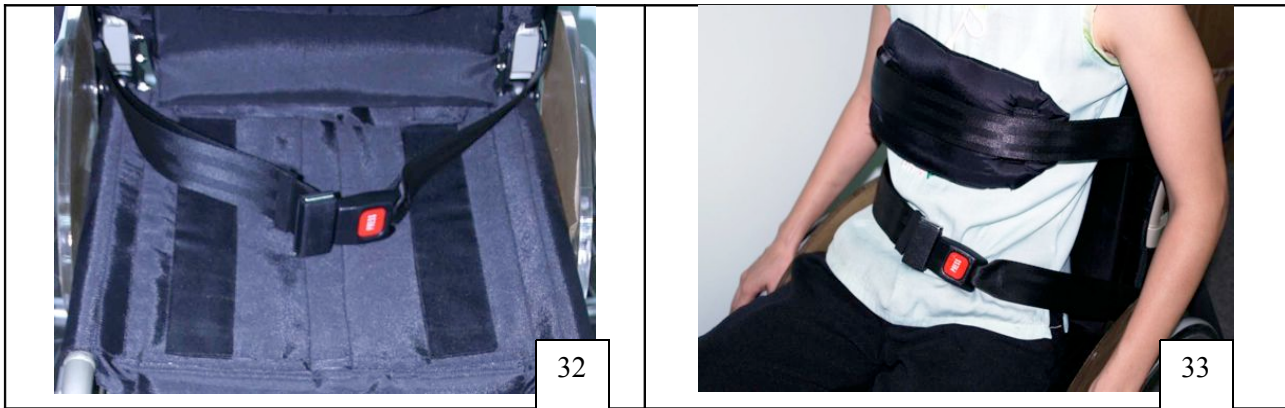

4. Pull upward (push forward) the handle of controller the wheelchair is operated for standing up.
5. Push downward (pull backward) the Handle of controller the wheelchair is operated for sitting down.

Note:

- Please make sure your hand not under the stand up mechanism.
- Make sure not children in the wheelchair back.

Chapter 6. CONTROL SYSTEM

6-1. The SHARK II Remote

Assembly of the remote

1. Battery gauge
2. ON/OFF
3. Activate / connect through / deactivate adjusting mode
4. Decrease speed
5. Speedometer
6. Horn
7. Increase speed
8. Attendant control LED
9. Service indicator LED
10. Joystick

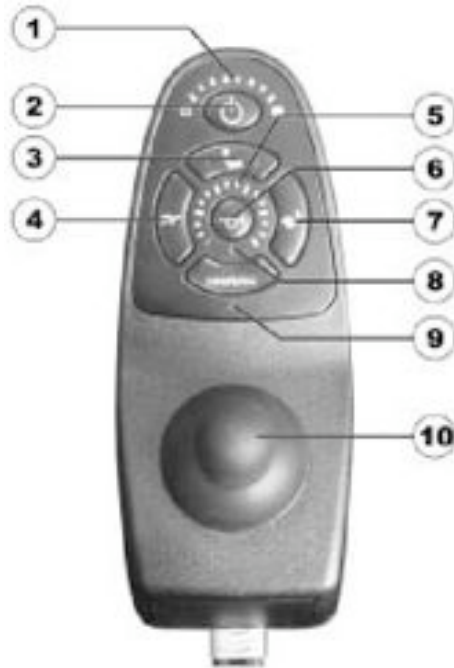

Lower side

1. Combined charging socket / programming socket



6-2. Battery and Control Connection

The main electrical control system is composed of motor, Control box battery and controller. The connection of control system as below.

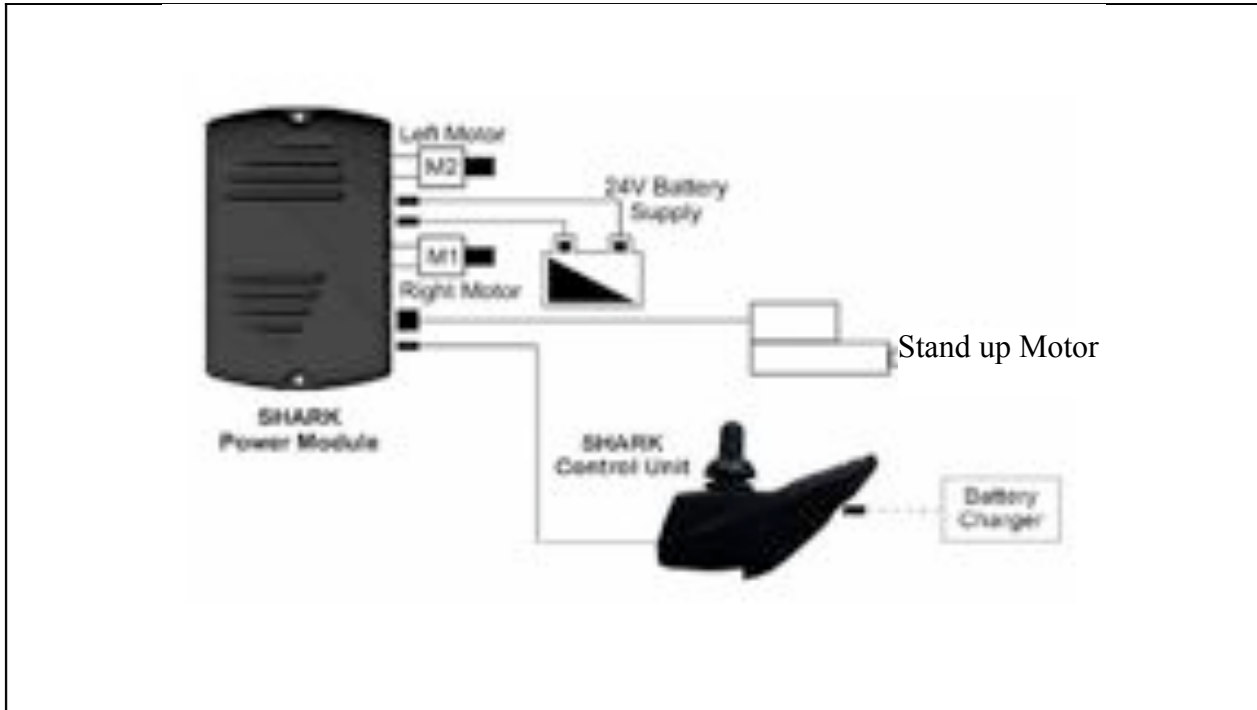

6-3. Battery Charge (Fig-34)

1. First, the battery charge line connects to the battery DC power socket and make sure the line is right connect.
2. Connect the AC power line to the AC socket. (110~220V)
3. The light of battery charger from yellow color, become green color and represent the battery charge in finish.

Battery capacity indictor color	Power condition	
Green	Full power	
Yellow	Low power	
Red	Empty power	

34

※ When the battery capacity is empty power, it will stop working.

Attention:

- 1. Anytime check the battery capacity.**
- 2 .New battery must charged over 8 hours.**
- 3.Charge your battery from the battery charger provided by manufacturer only.**

6-4. Main Circuit Breaker

The main circuit breaker reset button is located on the battery box. (Fig 35). The main circuit breaker monitors the electric current drawn form the battery. It is a safety feature built in your wheelchair for your extra safety. The entire electric system of the wheelchair is protected by the main circuit breaker against overloading.

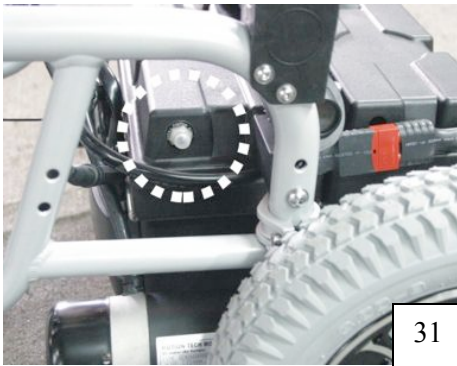

31

Chapter 7. MAINTENANCE

- When cleaning your XO-202 series use a dry or slightly moistened cloth to wipe the wheelchair down. For stubborn or oily stains, apply a mild detergent to the cloth. Do not hose down your XO-202 series with water.
- According to frequency of use, check tire pressure between once a week and once a month. If necessary, pump up the tires in line with manufacturer's recommendations.
- Check the state of the tread on the tires every one to six months. If a tire is heavily or unevenly worn, it should be replaced.
- Every one to six months, check that the brakes still work cleanly. Having applied the brakes, the wheels should stop turning completely. If the brakes are ineffective, they should be tightened up.
- According to frequency of use, to lubricate the joint between one a week and once a month. (Fig-32~34)

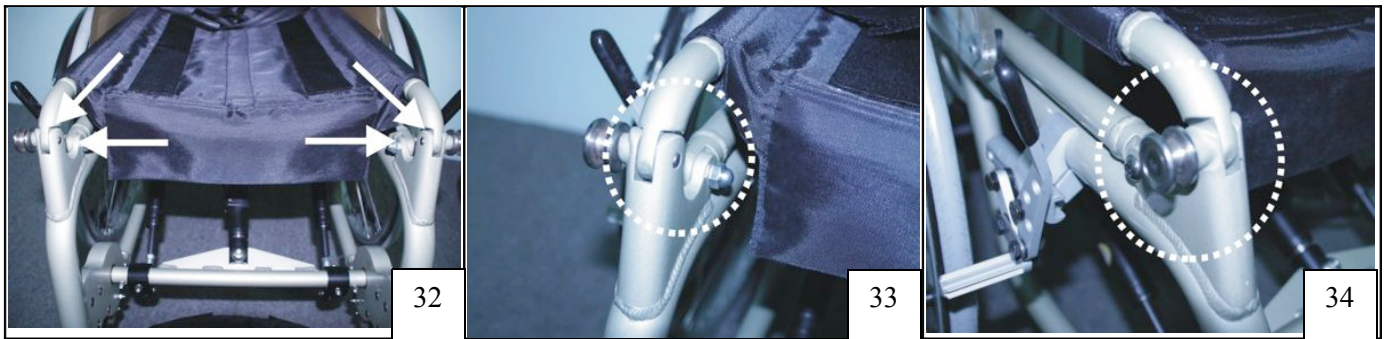

WARNING!

To inspect or replace the motor brushes:

1. Unscrew the motor brush caps. (See Fig 35)
2. Remove the brushes.
3. Inspect the brushes for wear (See Fig 36)
4. Replace the brushes if necessary.

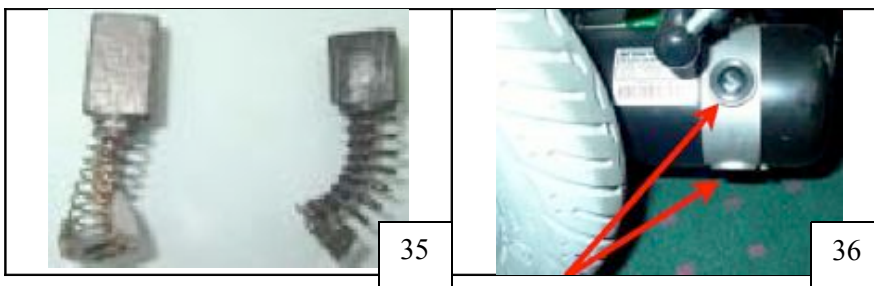

FLASH CODES



Flash codes indicate the nature of an abnormal condition directly from the SHARK Information Gauge. Without the use of any servicing tools, the condition can be simply diagnosed.

Flash Code	Description	
1	User Fault	Possible stall timeout or user error. Release the joystick to neutral and try again.
2	Battery Fault	Try charging the batteries. Batteries may require replacing. Check the batteries and cabling.
3	Left Motor Fault	Check the left motor, connections and cabling.
4	Right Motor Fault	Check the right motor, connections and cabling.
5	Left Park Brake Fault	Check the left park brake, connections and cabling.
6	Right Park Brake Fault	Check the right park brake, connections and cabling.
7	SHARK Remote Fault	Check the SHARK Communications Bus connections and wiring. Replace the Remote.
8	SHARK Power Module Fault	Check SHARK connections and wiring. Replace the Power Module.
9	SHARK Communications Fault	Check Battery voltage is greater than 17V. Check SHARK Bus Cable. Replace the SHARK Power Module. Replace the SHARK Remote.
10	Unknown Fault	Check all connections and wiring. Consult a service agent.
11	Incompatible Remote	The Remote is incompatible with the Power Module. Ensure the brand of the power Module matches that of the remote.

WARRANTIES

<u>Frame</u>	<u>Electrical</u>	<u>Parts</u>	<u>Motor/Transaxle/Brake</u>
3 Years	1 Year	6 Months	1 Year

1. Structural frame components including platform, fork, seat post and frame welds are warranted, to the original owner
2. To present a claim, Customer shall deliver the defective part for exchange or repair if possible to an Authorized Karman provider.
3. This warranty is for the replacement or repair, at the option of Karman Healthcare Inc., of defective parts only and does not cover any labor charges including, but not limited to, charges incurred for installation of replacement parts or additional fees, which may be imposed by Karman Healthcare Inc.
4. All warranty replacement parts are under warranty from the date of purchase of the original "product" and not from the date of part replacement.
5. This warranty is valid and enforceable only on "products" purchased in the United States and from a Karman provider.
6. This warranty is applicable only to the customer as an original purchaser of the "product" from an Authorized Karman provider and shall not apply to any subsequent purchaser, assignee or other recipient of the power chair from customer.
7. No provider or other similar person has any authority to make any warranties or representations concerning Karman Healthcare Inc. products, or to extend this warranty beyond the expressed terms contained within. Distributor assumes no responsibility for any warranties beyond the expressed terms contained in the warranty. Customer releases and holds distributor harmless from any claims stemming from any unauthorized representations.
8. This warranty does not apply unless the registration Card is signed, completed and returned within thirty days (30) from the date of purchase.
9. Warranty Exceptions:
 - A. Transaxle: In cases where there is an increase in the operational noise level, the warranty will not apply.
 - B. Motor: If damage occurs as a result of not replacing motor brushes after heavy wear to brushes.
10. This warranty does not cover batteries or damage caused by battery leakage. The battery manufacturer covers warranty.
11. This warranty does not cover plastic covers, seat upholstery, tires, or armpads these are considered wear items.
12. All transportation costs and shipping damage incurred while submitting parts for repair or replacement are the responsibility of the original purchaser.
13. This warranty does not apply to any injury, loss, defect or malfunction of the "product" or failure to function resulting from any failure to operate or maintain "product" in accordance with the directions contained in the owners manual provided by Karman; or any injury, loss, damage or malfunction, or failure to function resulting from any accident, acts of God, alterations in the "product" by anyone other than the distributor, or misuse, unreasonable use, tampering, abuse, acts, omissions, failure or negligence by anyone other than the manufacturer.