

# SILVER BOOM 250

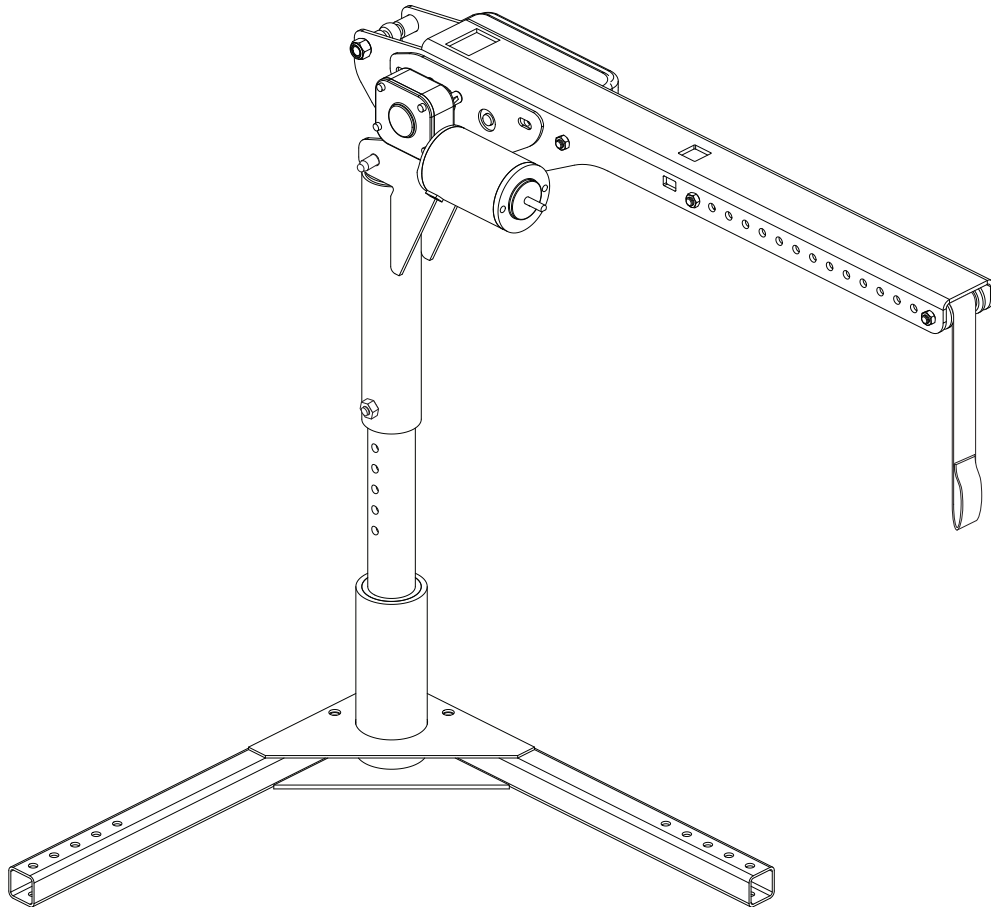

OWNER'S MANUAL

# SAFETY GUIDELINES



**WARNING!** An authorized Pride Provider or qualified technician must perform the initial setup of this lift and must perform all of the instructions in this manual.

The symbols below are used throughout this owner's manual and on the product to identify warnings and important information. It is very important for you to read them and understand them completely.



**WARNING!** Indicates a potentially hazardous condition/situation. Failure to follow designated procedures can cause either personal injury, component damage, or malfunction. On the product, this icon is represented as a black symbol on a yellow triangle with a black border.



**MANDATORY!** These actions should be performed as specified. Failure to perform mandatory actions can cause personal injury and/or equipment damage. On the product, this icon is represented as a white symbol on a blue dot with a white border.



**PROHIBITED!** These actions are prohibited. These actions should not be performed at any time or in any circumstances. Performing a prohibited action can cause personal injury and/or equipment damage. On the product, this icon is represented as a black symbol with a red circle and red slash.

Please fill out the following information for quick reference:

Pride Provider: _____
Address: _____
Phone Number: _____
Purchase Date: _____ Serial Number: _____

*NOTE: This owner's manual is compiled from the latest specifications and product information available at the time of publication. We reserve the right to make changes as they become necessary. Any changes to our products may cause slight variations between the illustrations and explanations in this manual and the product you have purchased. The latest/current version of this manual is available on our website.*



Copyright © 2011

Pride Mobility Products Corp.

INFMANU4128/Rev A/June 2011

# CONTENTS

<b>I. INTRODUCTION</b> .....	4
<b>II. SAFETY</b> .....	5
<b>III. INSTALLATION</b> .....	8
<b>IV. OPERATION</b> .....	12
<b>V. TROUBLESHOOTING</b> .....	14
<b>VI. CARE AND MAINTENANCE</b> .....	15
<b>VII. WARRANTY</b> .....	16

# I. INTRODUCTION

Welcome to Pride Mobility Products. Congratulations on the purchase of your new Silver Boom 250. The Silver Boom 250 design combines the most advanced state-of-the-art components with modern, attractive styling. We are certain that the design features and trouble-free operation will add convenience to your daily living and ensure complete satisfaction.

At Pride, your safety is important to us. **Please read and follow all instructions in this manual before operating your Silver Boom 250 for the first time.** These instructions were produced for your benefit. Your understanding of these instructions is essential for the safe operation of your new Silver Boom 250.

Pride is not liable for damage to property or personal injury arising out of the unsafe use of a Pride Silver Boom 250. Pride is also not liable for any property damage or personal injury arising out of the failure of any person and/or user to follow the instructions and recommendations set forth in this manual or any other instructions or recommendations contained in other Silver Boom 250 related literature issued by Pride or contained on the Silver Boom 250 itself.

## **INTERNET AND PRIVATE PURCHASES**

If you purchased your product over the Internet or from a previous owner and you have any questions about the safe use and/or maintenance of the product, please visit the Pride web page at **www.pridemobility.com** or contact your authorized Pride Provider.

## **PURCHASER'S AGREEMENT**

By accepting delivery of this product, you promise that you will not change, alter, or modify this product or remove or render inoperable or unsafe any guards, shields, or other safety features of this product; fail, refuse, or neglect to install any retrofit kits from time to time provided by Pride to enhance or preserve the safe use of this product.

## **INFORMATION EXCHANGE**

We want to hear your questions, comments, and suggestions about this manual. We would also like to hear about the safety and reliability of your new Silver Boom 250, and about the service you received from your authorized Pride Provider.

Please notify us of any change of address, so we can keep you apprised of important information about safety, new products, and new options that can increase your ability to use and enjoy your Silver Boom 250. Please feel free to contact us at the address below:

### **USA:**

Pride Mobility Products Corporation  
182 Susquehanna Ave.  
Exeter, PA 18643-2694

### **Canada:**

Pride Mobility Products Company  
380 Vansickle Road, Unit 350  
St. Catharines, Ontario L2R 6P7

***NOTE: If you ever lose or misplace your product registration card or your copy of this manual, contact us and we will be glad to send you a new one immediately.***

# II. SAFETY

## PRODUCT SAFETY SYMBOLS

The symbols below are used on the lift system to identify warnings, mandatory actions, and prohibited actions. It is very important for you to read and understand them completely.



**Read and follow the information in the owner's manual.**

**Maximum lifting capacity.**

**Do not sit on mobility product while operating the lift system or during transport.**



**Pinch/Crush points created during assembly and/or operation. Keep hands/fingers away from moving components during operation.**

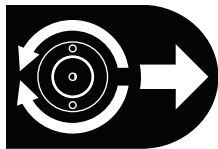

**Manual Override.**



**Contains Lead.**



**Do not extend the lifting strap past the warning label located on it.**

**Caution! Moving parts!**

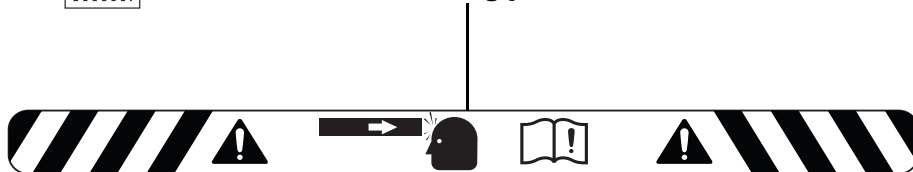

## II. SAFETY



**Disposal and recycling-Contact your authorized Pride Provider for information on proper disposal of your Pride product and its packaging.**

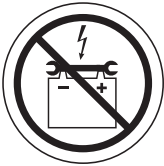

**Keep tools and other metal objects away from battery terminals. Contact with tools can cause electrical shock.**



**Do not allow unsupervised children to play near the lift while the batteries are charging.**



**Corrosive chemicals contained in battery.**



**Explosive conditions exist!**



**Use only AGM or Gel-Cell batteries to reduce the risk of leakage or explosive conditions.**



**Wear safety goggles.**



**Avoid exposure to rain, snow, ice, salt, or standing water whenever possible. Maintain and store in a clean and dry condition.**

## II. SAFETY

### LIFTING CAPABILITIES

The Silver Boom 250 is designed to lift a maximum weight of 250 lbs. (113 kg). Under no circumstances should the Silver Boom 250 be made to exceed this weight limit. Subjecting the Silver Boom 250 to the strain of lifting more than it is designed to may cause it to fail, resulting in damage to the mobility product and/or injury to the lift operator. Refer to the mobility product owner's manual for information on the overall weight of the mobility product before lifting with the Silver Boom 250.



**MANDATORY! Adding accessories, oversized batteries, or a different seat will increase the weight of your mobility device. Verify with your authorized Pride Provider that the total weight of your mobility device, including additions, DOES NOT exceed 250 lbs. (113 kg).**

### INSTALLATION

Your Silver Boom 250 Lift System is an exterior-rated lift designed for installation into vehicles. Read and fully understand the installation instructions provided in this manual and related literature for your brand of vehicle before installing the lift system. The distance between the top of the boom-arm and the mobility product should not exceed 50 in. (127 cm) when the boom-arm is fully extended.

### LIFTING NON-PRIDE PRODUCTS

The lift system is an extremely versatile device, which users may employ to lift items other than Pride products. Pride has no control over such use, nor can Pride anticipate every possible use to which a lift system may be put. Operating the lift system outside of the safe limits as discussed in this manual or using the lift system to lift any item deemed by Pride to be incompatible with the lift system is done at the operator's own risk, and Pride accepts no liability for damage or injury resulting from such use.

### PRELIFT INSPECTION

Inspect the lifting strap of the Silver Boom 250 before every use for twisting, fraying, and signs of wear. If signs of wear become evident, have the strap replaced by your authorized Pride Provider.



**WARNING! A frayed or worn lifting strap can snap, resulting in damage to the mobility product being lifted and injury to the lift operator.**

### OPERATOR POSITIONING

Keep hands clear of the lifting strap while the Silver Boom 250 is lifting/lowering a mobility product. The operator of the lift should stand a safe distance from the unit being lifted/lowered to ensure that his/her feet are never positioned under a raised mobility product.

### TRANSPORT VEHICLE POSITIONING

Be sure your vehicle is parked on flat, level ground and the emergency brake is engaged before attempting to lift a mobility product.



**WARNING! Attempting to lift a mobility product when a vehicle is not on level ground will cause the mobility product to swing toward or away from the vehicle, making it difficult to get the mobility product into the vehicle.**

# III. INSTALLATION

## SILVER BOOM 250 LIFT SYSTEM INSTALLATION

**NOTE:** *The Silver Boom 250 is an exterior-rated lift system. Refer to the online compatibility database located at [www.pridemobility.com](http://www.pridemobility.com) for information concerning lift system/vehicle compatibility, or contact your authorized Pride Provider.*



**WARNING!** The Silver Boom 250 Lift System should be installed by an authorized service technician only.

**WARNING!** At least two people should lift the Silver Boom 250 into the rear of the vehicle. Use proper lifting techniques and avoid lifting beyond your physical capability.



**WARNING!** Avoid pinch points! Do not hold the lift frame by the pivot points when installing the Silver Boom 250.

**NOTE:** *Use only the supplied hardware to install the Silver Boom 250 Lift System.*

**NOTE:** *To preserve vehicle-system data, the vehicle's power system may need to be connected to an alternate power source prior to battery removal. Refer to the vehicle's owner's manual for information on proper battery-disconnection instructions.*

**Follow these steps for installation:**

1. Install the Silver Boom 250 securement system to the vehicle.

**NOTE:** *Securement systems vary depending on vehicle manufacturer. Pride recommends use of the securement system provided with the lift only and that you follow all instructions provided by the manufacturer for installation.*

2. Connect the Silver Boom 250 to a power source. See "Wiring Harness Installation."

**NOTE:** *If your lift is equipped with an optional onboard battery, refer to "Optional Onboard Battery Pack Installation."*

3. Ensure that all mounting hardware is fully tightened and all required clearances have been achieved.

**NOTE:** *The Silver Boom 250 may include an optional set of L-Base extensions. For information on L-base extension installation, refer to the supplemental instructions or contact your authorized Pride Provider.*



# III. INSTALLATION

## BOOM-ARM ADJUSTMENT

The boom-arm can be adjusted for your convenience. See figure 1.

**NOTE:** If your Silver Boom 250 is equipped with an optional offset arm, follow the instructions below to make adjustments. See figure 3.

### To raise or lower the upper post:

1. Remove the nut and bolt from the upper post. See figure 1.
2. Raise or lower the upper post to the desired position, matching the adjustment holes of the upper post with the adjustment holes of the lower post.
3. Reinstall the bolt through the adjustment hole and secure it with the nut.

### To adjust lifting strap positioning:

The lifting strap can be adjusted in (toward the post) or out (away from the post) for convenience.

1. Remove the nuts from the threaded bolt that secure the strap to the boom arm. See figure 1.
2. Roll the strap to the desired position, aligning the strap roller with the desired adjustment hole in the boom arm. See figure 1.
3. Insert the threaded bolt through the adjustment hole and reinstall the nuts.

**NOTE:** The angle of the boom arm can be adjusted to accommodate certain height limitations. See figure 1.

**NOTE:** Do not force the threaded bolt into the adjustment hole.

### To lower the boom arm:

1. Remove the clevis pin located between the boom arm and upper post. Guide the boom arm downward until it is parallel with the upper post. See figure 4.
2. Reinsert the clevis pin into the top of the upper post to secure the boom arm in place. See figure 4.

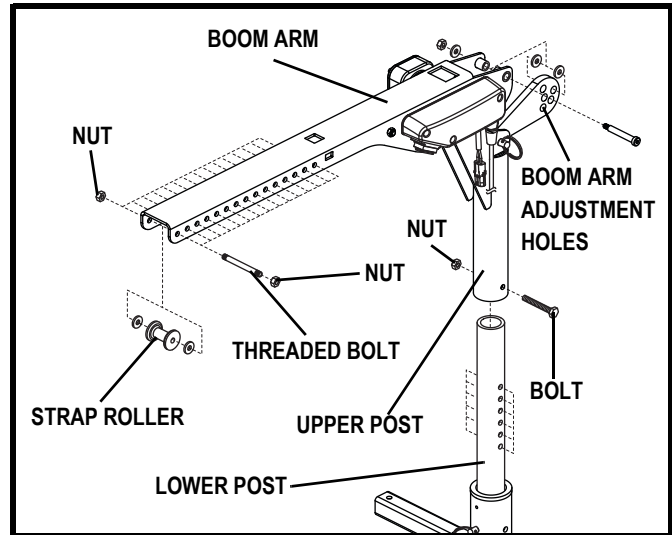

Figure 1. Upper Post Adjustment

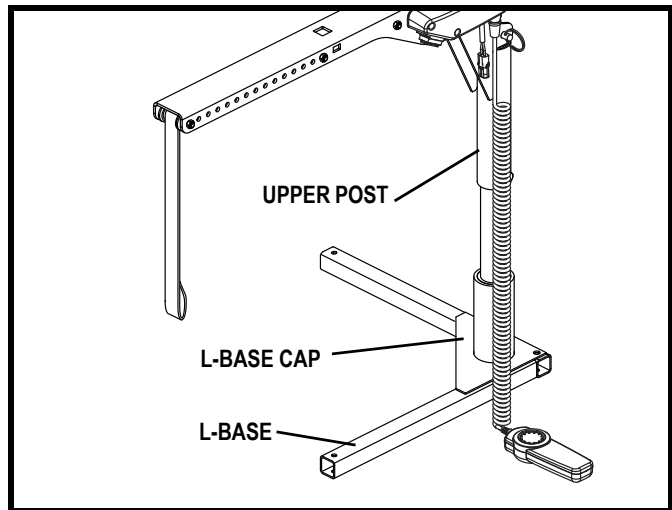

Figure 2. Fully Assembled Silver Boom 250

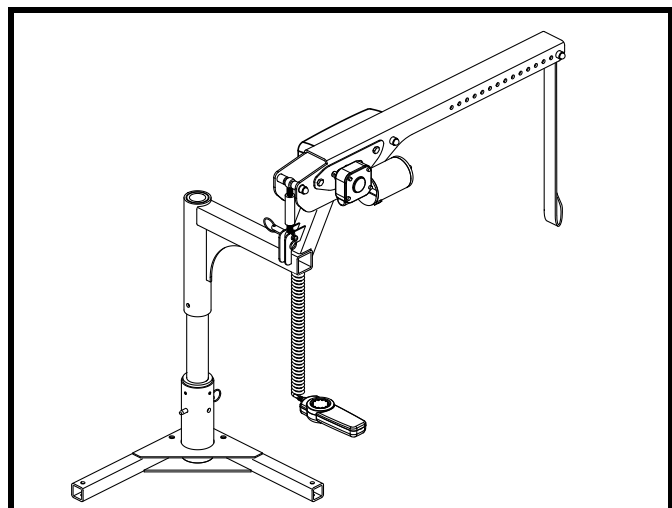

Figure 3. Optional Offset Arm

# III. INSTALLATION

## ELECTRICAL WIRING INSTALLATION

1. Route the hard wire kit (starting at the lift) through the interior of the vehicle until you reach the automobile battery. See figure 5. Conceal the wire behind or under the interior panels. Be certain that the wire is protected with a rubber grommet when passing it through the metal panels and into the engine compartment. Inside the engine compartment, secure the wire to the fire-wall and the inner fender with the supplied plastic wire ties. Use care not to cause abrasions to the power wire. It is important to secure the power wire at various points along its run.
2. Insert the red positive (+) lead on the power wire into the spliced end of the red positive (+) battery lead, then crimp the splice to secure the wire.
3. Connect the red positive (+) battery lead to the positive (+) battery terminal and the black negative (-) ground wire to the negative (-) battery terminal.

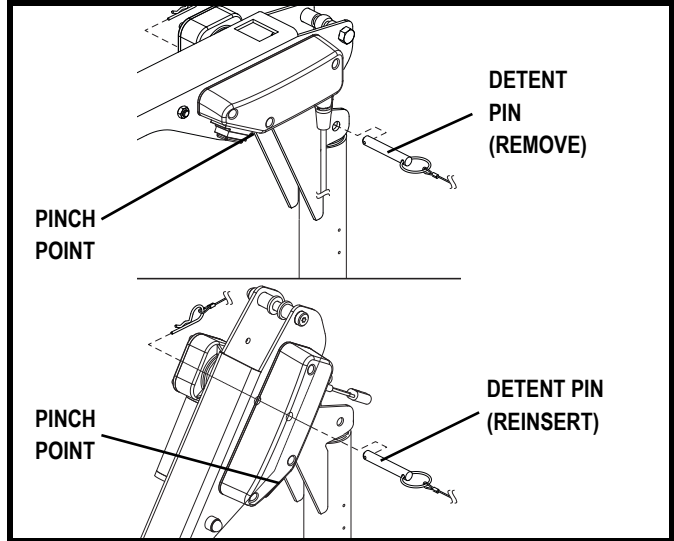

Figure 4. Securing The Boom Arm



**WARNING! The red positive (+) wire must be connected directly to the positive (+) battery terminal.**

**WARNING! The black negative (-) wire must be connected directly to the negative (-) battery terminal.**

4. Connect the harness extending from the motor housing to the harness coming from the battery.

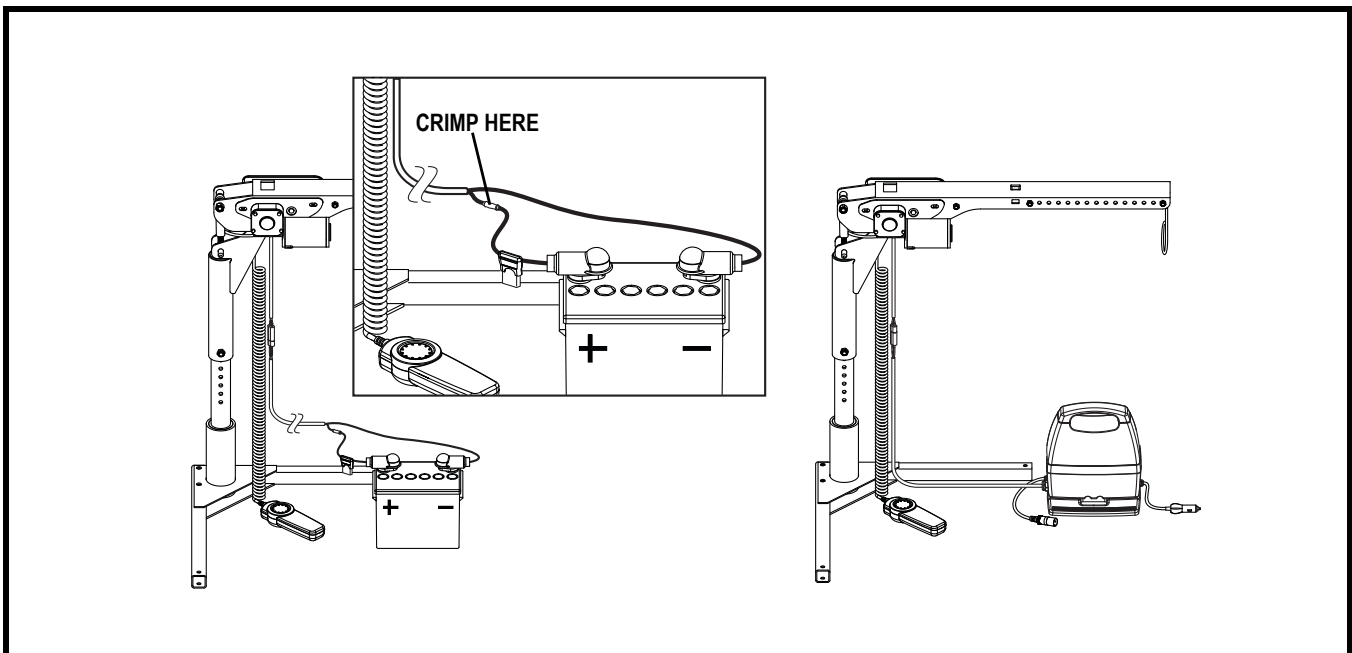

Figure 5. Electrical Wiring Connections

# III. INSTALLATION

## Optional Onboard Battery Pack Installation

The optional onboard battery is designed for easy installation as it does not require wires to be routed through or under the vehicle. Please refer to the manual supplied with the pack for proper operating instructions and harness connections.

### Follow these steps to install the onboard battery:

1. Insert the onboard battery into the battery pack base, making sure that the connector on the bottom of the battery aligns and fully connects with the mating connector inside the battery pack base. **See figure 6.**
2. Connect the male connector on the battery cable to the female connector at the base of the Silver Boom 250. **See figure 6.**
3. Secure the battery cable to the other cables with wire ties.

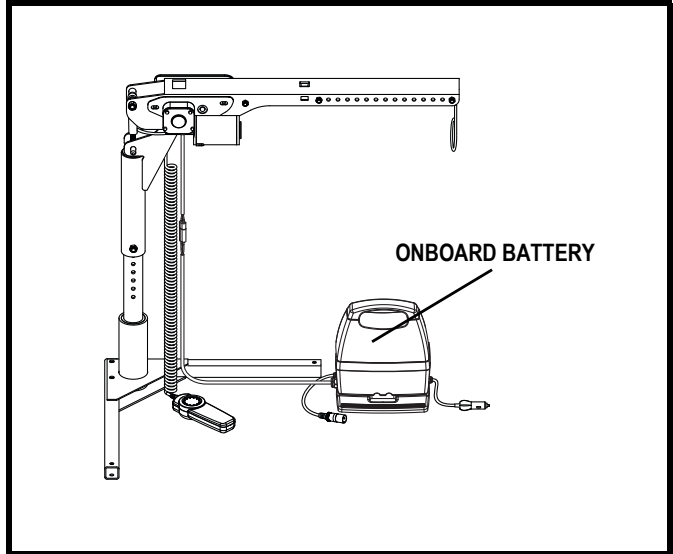

Figure 6. Onboard Battery Installation

# IV. OPERATION

## POWER SWITCH OPERATION

Your Silver Boom 250 is equipped with a power switch that enables/disables operation. Press UP to turn the power on; press DOWN to turn the power off. See figure 9.

**NOTE:** The ON/OFF switch also functions as the circuit breaker reset button. See figure 9.

## HAND CONTROL OPERATION

The hand control for the Silver Boom 250 operates the lifting strap in two directions: up and down. Press and hold the button until the desired position is attained. See figure 7.

**NOTE:** Store the hand control in the hand control bracket (located on the boom) after operation and during storage.

## LIFTING THE MOBILITY PRODUCT



**WARNING!** Before operating the Silver Boom 250 for the first time, be absolutely certain you have the proper docking device for your mobility product installed.

1. Prepare your mobility product for transport. Ensure that the power is off and properly secure the batteries. You may also need to lower the tiller and/or remove the seat.
2. Position your mobility product on the ground behind the installed lift. Be sure that there is ample space between the mobility product and the vehicle bumper to ensure that the mobility product will not hit the bumper while being raised. If the mobility product is too far from the vehicle's bumper, the mobility product will be dragged when attempting to lift it.
3. Position the boom-arm over the mobility product.
4. Operate the lift in the downward direction. The lift strap should drop straight down to the T-bar or docking device collar.



**WARNING!** Inspect the lifting strap before each use for twisting, fraying, and signs of wear.

**WARNING!** Avoid unloading into vehicular traffic.

**NOTE:** Keep tension on the lifting strap with your free hand when lowering the boom-arm.



**WARNING!** Do not extend the lifting strap past the warning label located on it.

5. Ensure that the docking device is properly attached.
6. Operate the lift in the upward direction.

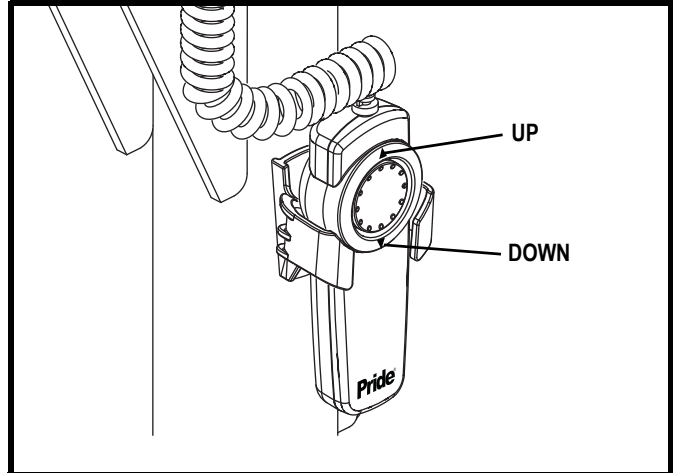

Figure 7. Hand Control

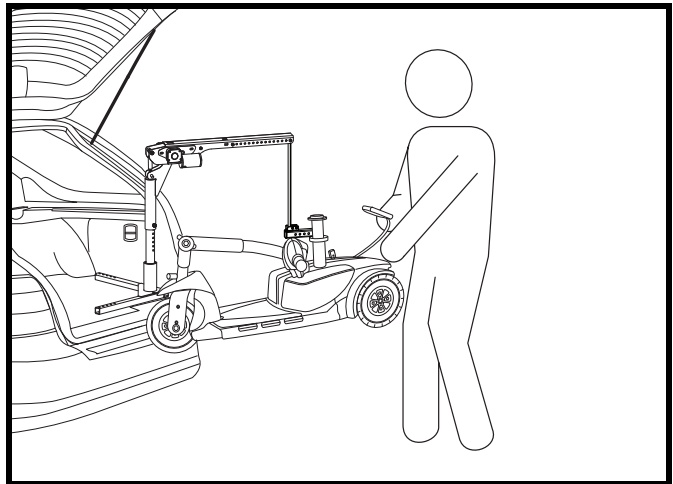

Figure 8. Lifting The Mobility Product

## IV. OPERATION



**WARNING! Pinch/Crush Hazard!** Always keep hands clear of the lifting strap while the Silver Boom 250 is lifting/lowering a mobility product. The operator of the lift should stand a safe distance away from the mobility product being lifted/lowered to ensure that feet are never positioned under a raised mobility product.

**NOTE:** Do not drag the mobility product into position using the lift. If dragging occurs, your mobility product is too far away from the vehicle.

### To prevent dragging:

- Release the lifting strap tension.
- Correct the position of the mobility product.
- Attempt the lift again.

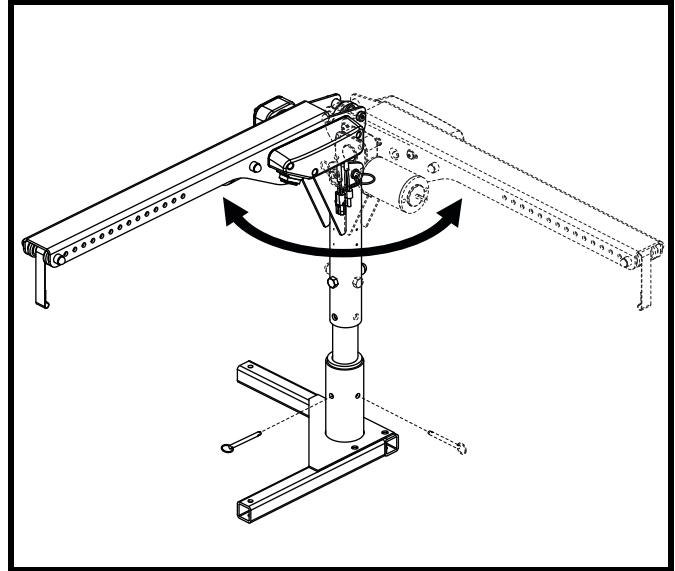

Figure 9. Securing the Boom Arm to Prevent Swinging



**MANDATORY!** The Silver Boom 250 is designed to lift a maximum weight of 250 lbs. (113 kg). Do not exceed this limit.

7. If the mobility product begins to tilt, lower it completely and adjust the docking device by moving the pick-up bar in the direction of the tilt (when using a C-arm).
8. Tighten the pick-up bar once the proper balance point has been found (when using a C-arm).
9. Once the mobility product is raised high enough to fit into the vehicle, stop the lift. **See figure 8.**
10. Swing the boom-arm toward the vehicle. When the mobility product is securely in the vehicle, lower the lift strap until all of the mobility product wheels are on a solid surface.

**NOTE:** Ensure the mobility device is secured against slipping once installed in the motor vehicle.

11. Shut off the Silver Boom 250 to prevent any accidental movement when transporting your mobility product.



**WARNING!** Your Silver Boom 250 was designed to be mounted primarily in a motor vehicle. Mounting your Silver Boom 250 on a platform, where the height of the lift may cause the lifting strap to extend beyond a safe point, can damage the Silver Boom 250 and injure the lift operator.



**MANDATORY!** Secure the boom-arm so it does not swing during transport. A swinging boom-arm can be a hazard.



**WARNING!** Do not overtighten the strap. Doing so may put excessive strain on the motor, causing the circuit breaker to trip.

# V. TROUBLESHOOTING

## LIFT WILL NOT OPERATE

- Check the circuit breaker reset button. Reset if necessary. See figure 10.
- If the circuit breaker reset button is not tripped, check the hardwire fuse to see if it is blown. Replace if necessary. See figure 11.
- Ensure all harness connections are secure.
- Ensure the power wire leading to the positive battery terminal is tight and not corroded.
- Check the fuse located on the red power wire near the battery. If blown, replace with a new 15-amp fuse. See figure 11.

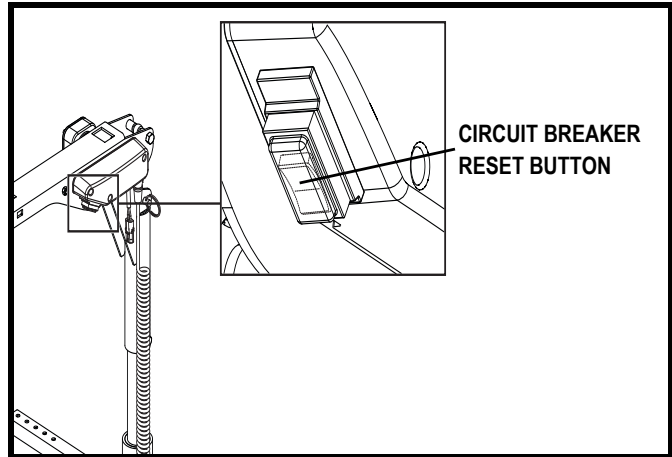

Figure 10. Circuit Breaker Reset Button



**WARNING!** The replacement fuse must exactly match the rating of the old fuse. Failure to use properly rated fuses may cause damage to the electrical system.

## LIFT STOPS OPERATING

If your Silver Boom 250 is heavily strained because of excessive loads, the main circuit breaker (see figure 10) may trip to protect the motor and electronics from damage. When the breaker trips, the entire electrical system shuts down.



**WARNING!** Never attempt to lift more than 250 lbs. (113 kg) with the Silver Boom 250.

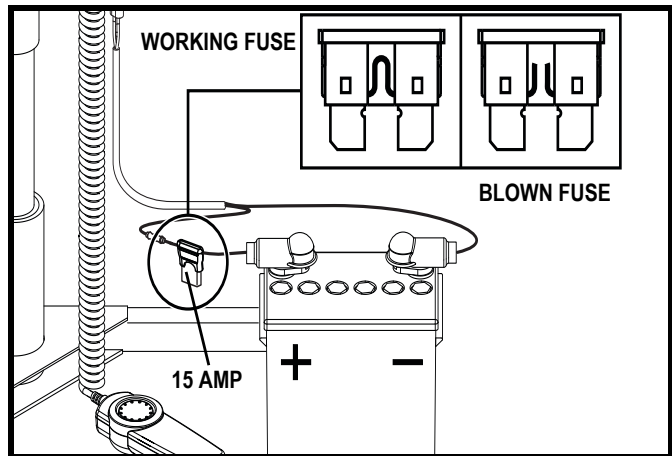

Figure 11. Hardwire Fuse

### To reset the main circuit breaker:

1. Allow a minute or so for the electronics to “cool.”
2. Push in the reset button to reset the breaker. See figure 10.

If the breaker trips frequently, contact your authorized Pride Provider.

## LIFTING STRAP TRAVELS IN OPPOSITE DIRECTION OF BUTTON BEING PUSHED ON HAND CONTROL

Before each use, check that the lifting strap is traveling in the proper direction. If the belt travels in the wrong direction when you press either the up or down button, you must restore proper lifting strap travel.

### To restore proper lifting strap travel:

1. Pull slightly on the strap and operate the lift until the strap is extended completely past the “stop” warning label.
2. Allow the strap to rewind itself. Do not allow any twists in the belt.

Observe the travel of the belt, which should correspond with the button being pushed on the hand control. If you are still experiencing problems, contact your authorized Pride Provider.

## VI. CARE AND MAINTENANCE

The following routine maintenance should be performed at the indicated intervals. Failure to perform the required maintenance procedures at the required intervals may void Pride's product warranty.

### **Perform prior to daily use:**

- Inspect lift strap wear and replace if necessary.
- Inspect all external electrical connectors for damage and replace if necessary.

### **Perform every 6 months:**

Inspect all mounting hardware for defects and a secure fit. Any hardware found to be loose should be tightened or replaced if necessary.

### **Perform every 6 – 12 months:**

- Remove upright post and lubricate with "General Purpose Petroleum Based Grease".
- Visually inspect chains for damage and replace if necessary.
- Lubricate chains with "General Purpose Petroleum Based Grease".
- Inspect plastic shrouds for cracks or damage and replace if necessary.

# VII. WARRANTY

## **THREE-YEAR TRANSFERABLE LIMITED WARRANTY**

For three (3) years from the date of purchase, Pride Mobility Products will repair or replace at our option, free of charge, any mechanical or electrical component found upon examination by an authorized representative of Pride Mobility Products to be defective in material and/or workmanship.

This warranty does not extend to those items, which may require replacement due to normal wear and tear.

- Labor, service calls, shipping, and other charges incurred for repair of the product, unless specifically authorized by Pride Mobility Products IN ADVANCE, are excluded.

**Exclusions also include components with damage caused by:**

- Contamination
- Abuse, misuse, accident, or negligence
- Battery fluid spillage or leakage
- Commercial use, or use other than normal
- Improper operation, maintenance, or storage
- Repairs and/or modifications made to any part without specific consent from Pride Mobility Products Corporation.
- Circumstances beyond the control of Pride

## **ONE-YEAR WARRANTY**

The battery is covered by a separate one (1) year warranty provided by the battery manufacturer. The batteries are not warranted by Pride Mobility Products.

## **SERVICE CHECKS AND WARRANTY SERVICE**

An authorized Pride Provider must perform warranty service. Do not return faulty parts to Pride Mobility Products without prior written authorization. All transportation costs and shipping damage incurred while submitting parts for repair or replacement is the responsibility of the purchaser.

Failure to follow the instructions, warnings, and notes in the owner's manual and those located on your Pride lift product can result in personal injury or product damage and will void Pride's product warranty.

There is no other express warranty.

## **IMPLIED WARRANTIES**

**Implied warranties, including those of merchantability and fitness for a particular purpose, are limited to one (1) year from the date of purchase and to the extent permitted by law. Any and all implied warranties are excluded.** This is the exclusive remedy. Liabilities for consequential damages under any and all warranties are excluded.

Some states do not allow limitations on how long an implied warranty lasts or do not allow the exclusion or limitation of incidental or consequential damages. The above limitation or exclusion may not apply to you.

This warranty gives you specific rights, and you may also have other rights, which vary from state to state.

Please fill out and return the product registration card to Pride Mobility Products. This will aid Pride in providing the best possible technical and customer service.



# NOTES

# NOTES



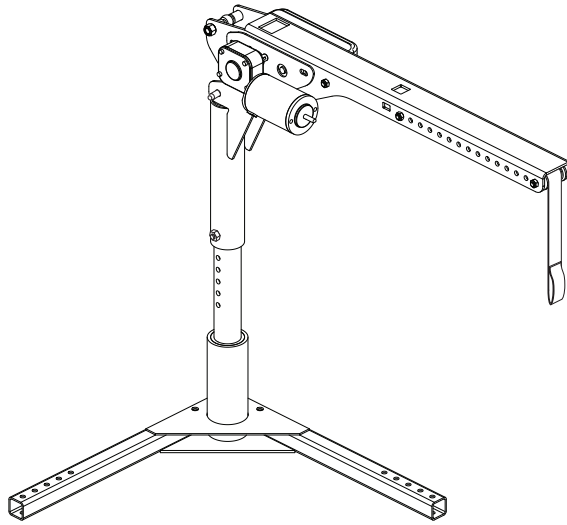

# ***Pride® Lifts & Ramps***