

TITAN 600



Item# F-600TLNA

The Titan 600 lift provides the highest lifting capability of any standard pool lift on the market with a 600 pound weight capacity. The unique, heavy duty design and anchoring system gives all patients and individuals the ability to enjoy the benefits of aquatic exercise, therapy, and play!



**Solar
Charger**



U.S. Patent No.
D507,769 S

ROTATIONAL SERIES

ITEM

DESCRIPTION

F-600TLNA

The Titan 600 Lift, no anchor

ACCENT COLORS

Available in a variety of accent and powder coat colors



*Blue seat standard (not a powder coat option)

OPTIONS/ACCESSORIES:

F-612TLA	Anchor, standard 3-1/4" ID x 8" deep
F-720SSC	Cover, standard lockable, blue
F-720SSC-G	Cover, standard lockable, gray
F-720SSC-T	Cover, standard lockable, tan
F-422PLH-2	Headrest
F-105LAR	Pull-out leg rest
F-045SCH	Solar charging station

FEATURES:

- Independent third party verified to meet ADA standards by Wyle Labs
- 600 lb (272 kg) weight capacity
- Clearances vary by wall height & width
- Setback range 21" - 35" (54 - 89 cm)
- 360 degree powered rotation in either direction
- 22" wide (56 cm) seat
- Flip-up armrests
- Five year structural warranty
- Five year pro-rated electronics warranty

PROUDLY SOLD BY:

THE TITAN LIFT

PRODUCT SPECIFICATIONS

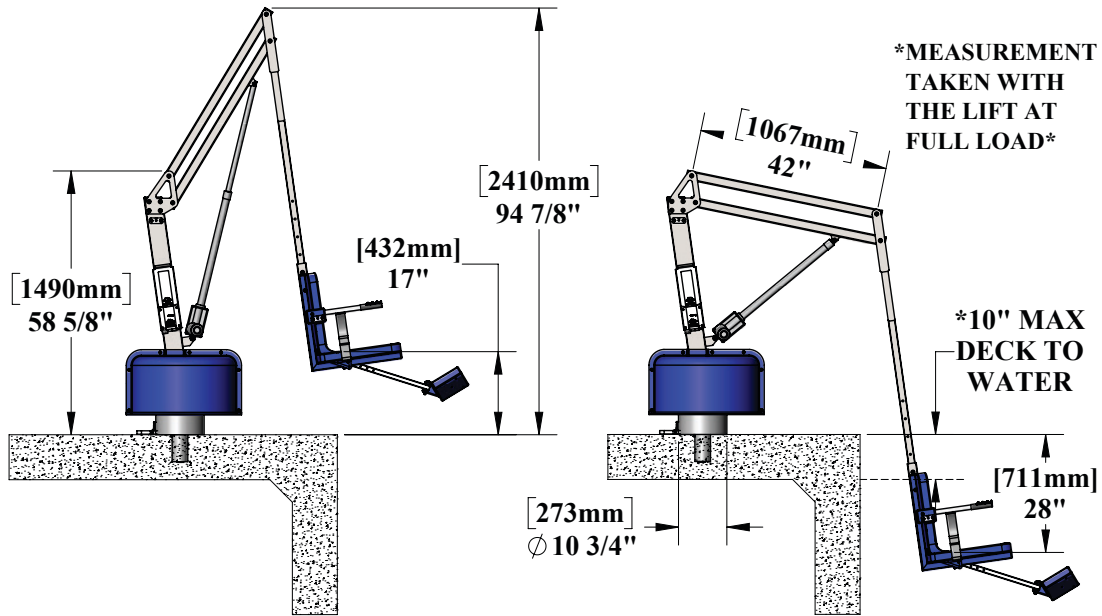

APPLICABLE POOL PROFILES

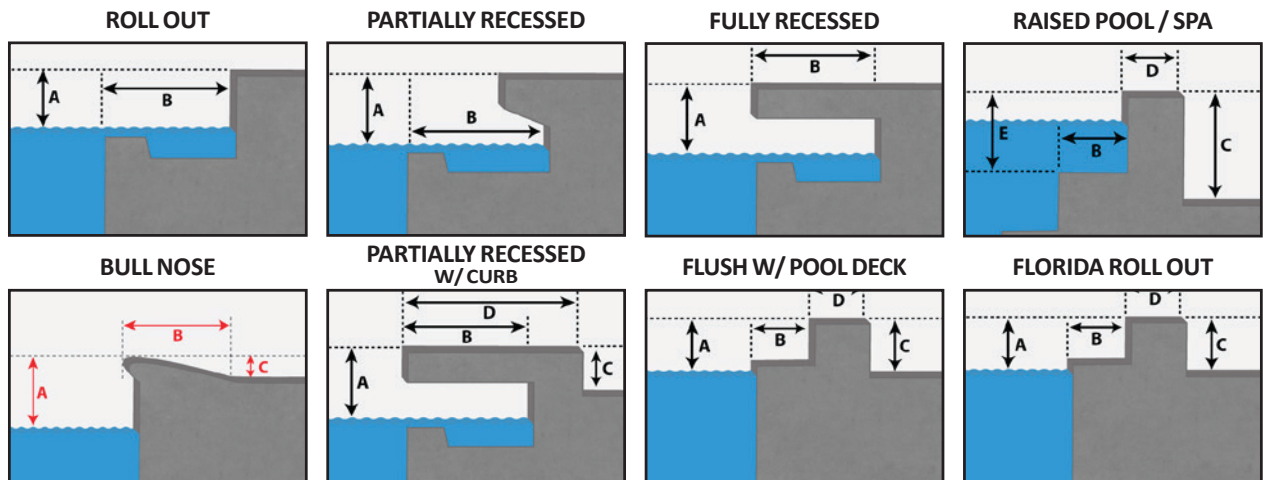

*provide measurements indicated to confirm application or use online pool lift selector

To confirm specific application go to www.aquacreek.com for our Pool Lift Selector
 Become a member of our new Dealer and Architect page. Access to CAD blocks,
 CSI specs and sales materials.